

INTRODUCTION TO VIKING RANGER II ASSEMBLY DETAILS

Component locations and terminal numbers are obtained from the line drawings and photos of the chassis at various stages of assembly. Component mounting feet or terminals referred to as "inside" are located nearest the center of the chassis, those referred to as "outside" are furthest from the center of the chassis. The individual terminals of terminal strips are not marked but for identification, are arbitrarily assigned consecutive numbers, the terminal nearest the center of the chassis being #1. Note that hardware sequence drawings give order of assembly and specify the size hardware to be used.

Individual socket contacts are numbered consecutively in a clockwise direction when looking at the bottom of the socket. Each contact has an identifying number molded into the socket body. Potentiometer terminals are unmarked but have been arbitrarily assigned consecutive numbers in a clockwise direction when viewed from the rear. Switch terminals are numbered consecutively in a clockwise direction when viewed from the front or shaft end.

Resistor and capacitor lead lengths are not generally given. These components, which are supported by their wire leads, have been positioned so as to provide short leads, good separation between leads and components to avoid the possibility of accidental grounds and shorts and good mechanical stability. Cut off excess lead lengths.

A number of operations in these instructions require that point to point connections be made using #20 plastic insulated hookup wire furnished with the kit. After cutting the lead to the specified length, strip 5/16" of insulation off both ends before attempting to install the lead.

The letter (S) appearing in the instructions means "solder", and letters (NS) "do not solder". When instructed to "tin" stranded leads, coat the ends lightly with solder to prevent breaking off loose strands and to make the leads easy to insert into terminals.

Read each operation thru and be sure it is understood before attempting to perform it. After completing each operation, check it off in the box () provided. To save time and insure a neat job, make liberal use of all drawings and photographs furnished.

Hardware sequence drawings appear on the reverse side of this sheet.

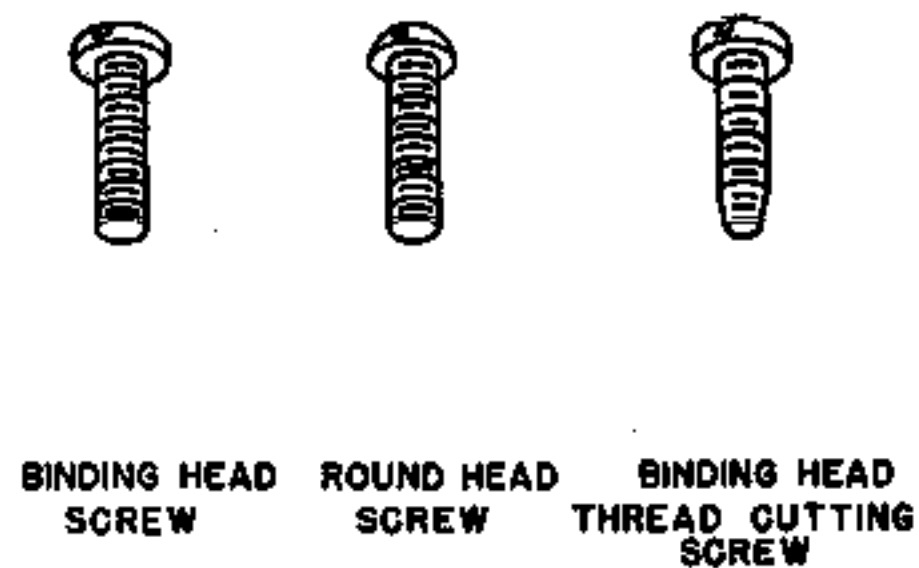
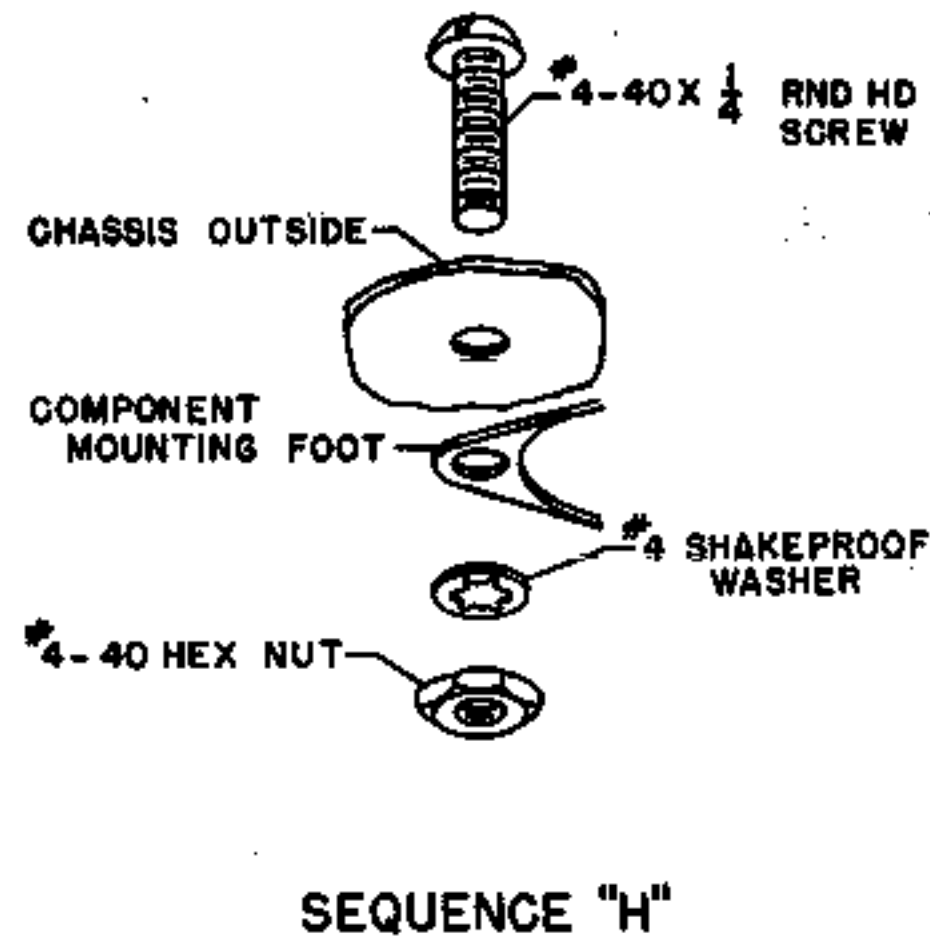
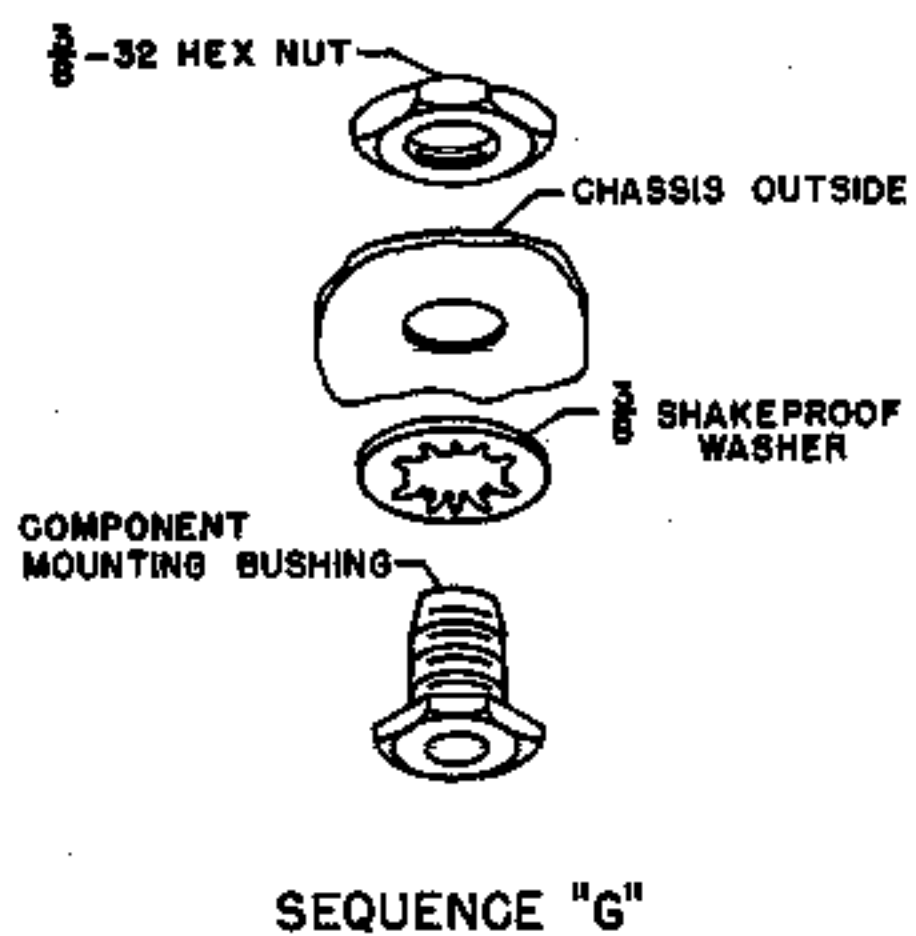
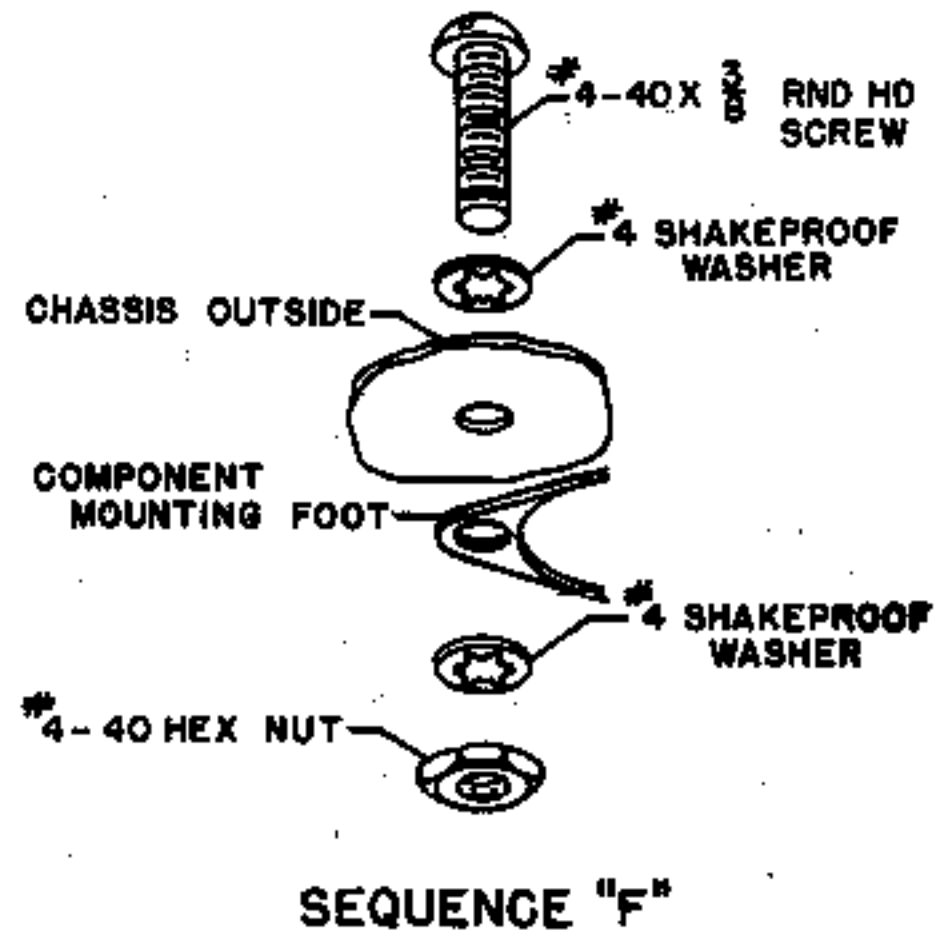
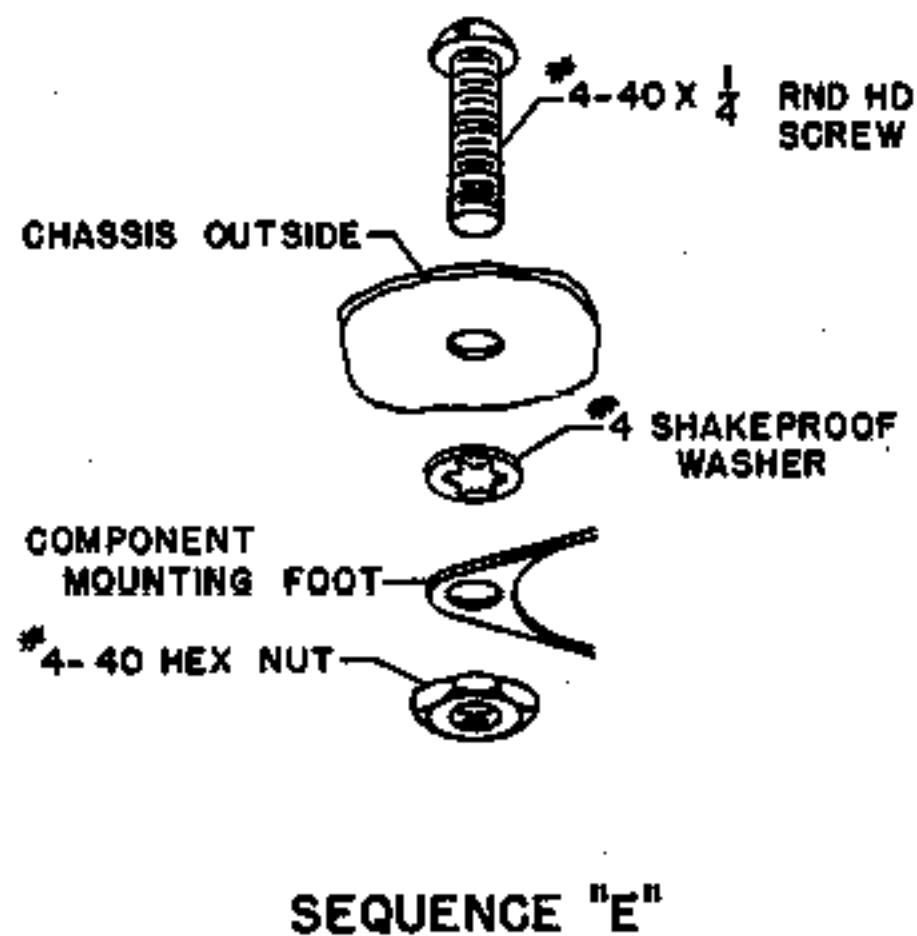
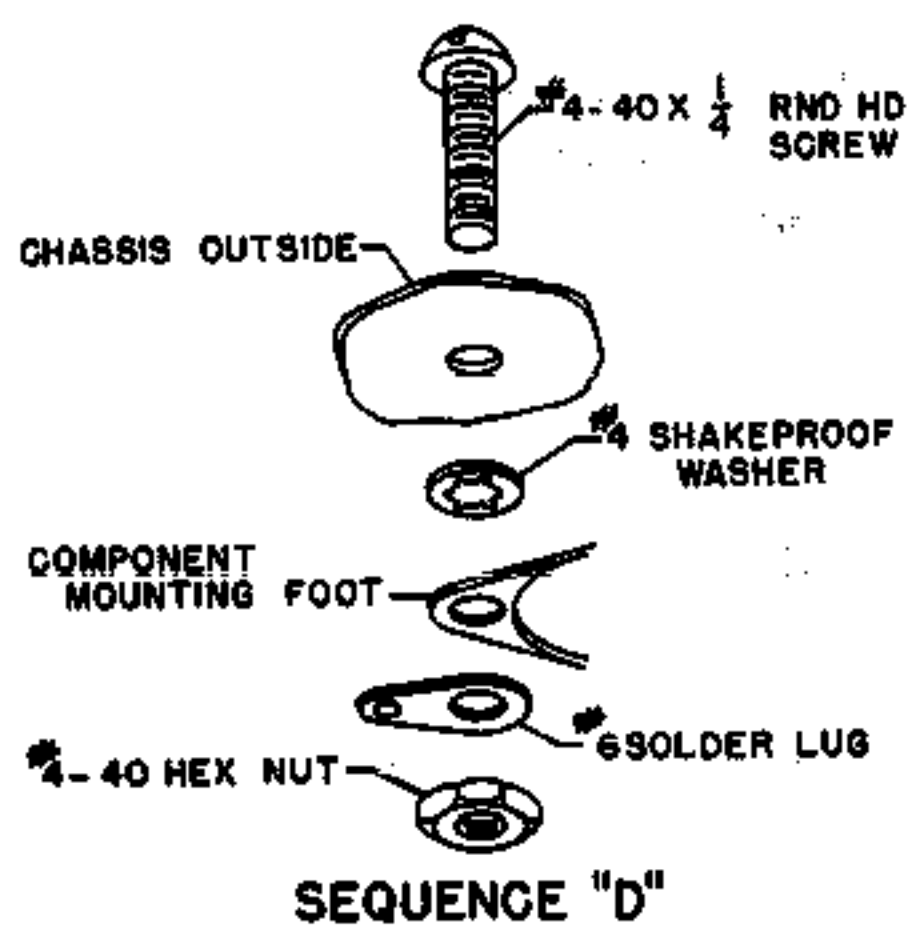
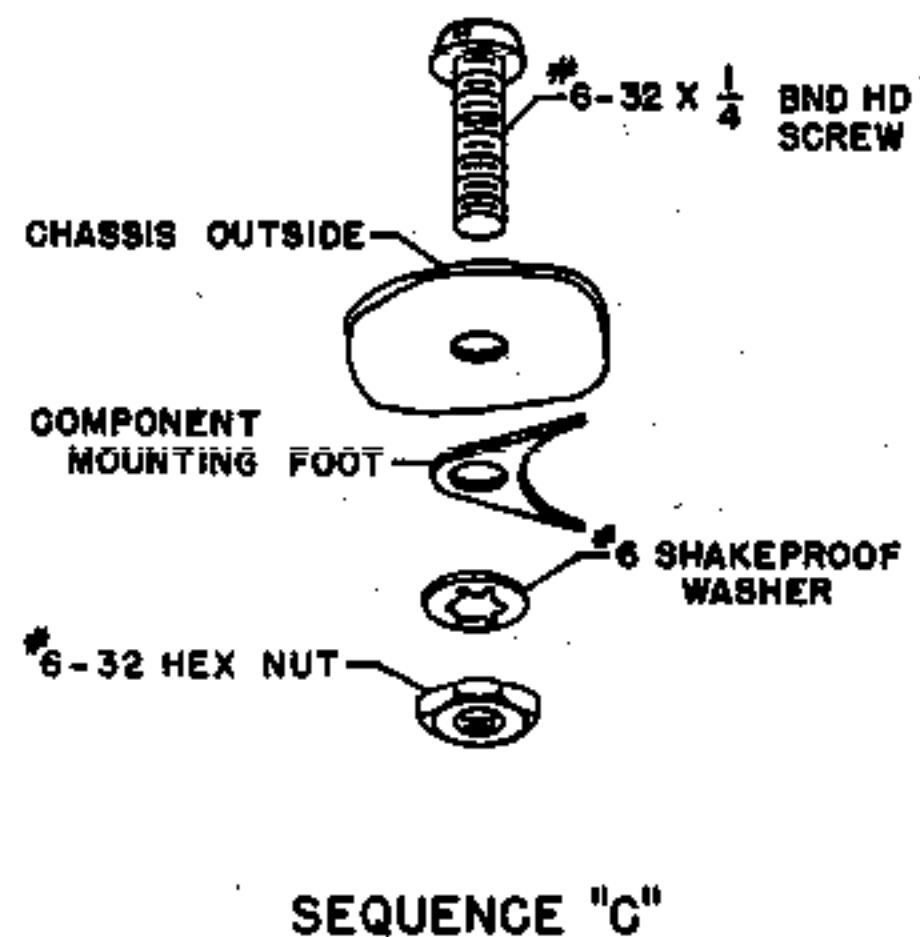
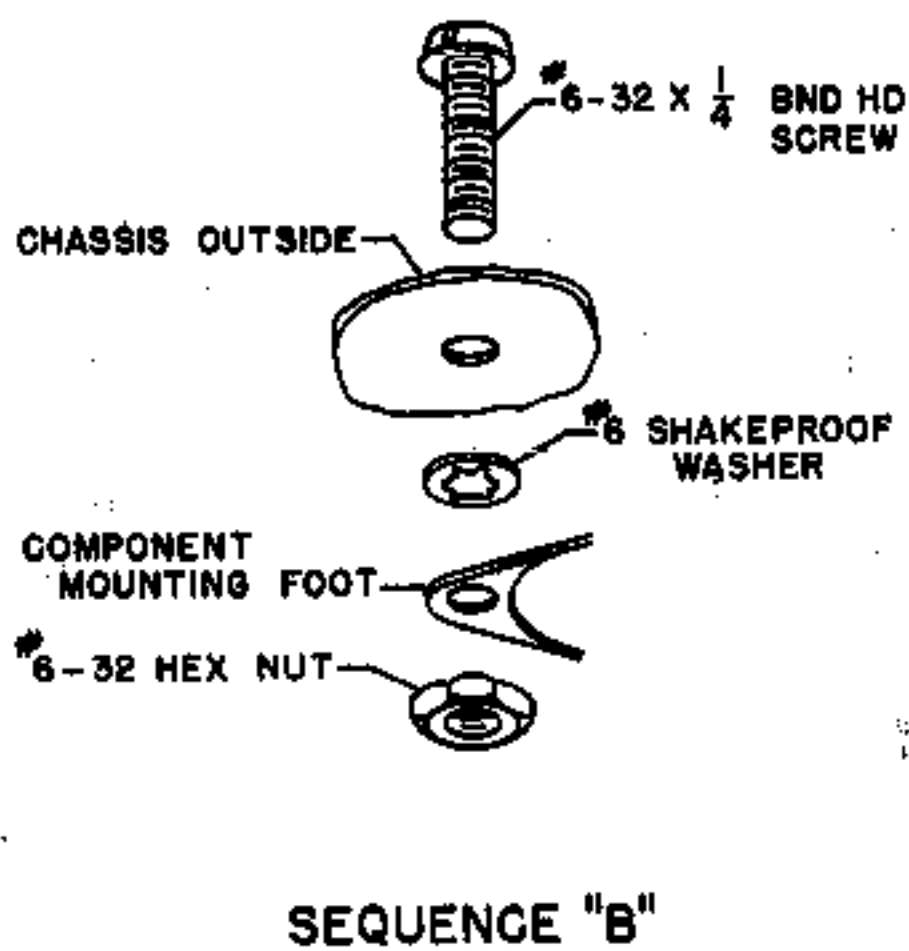
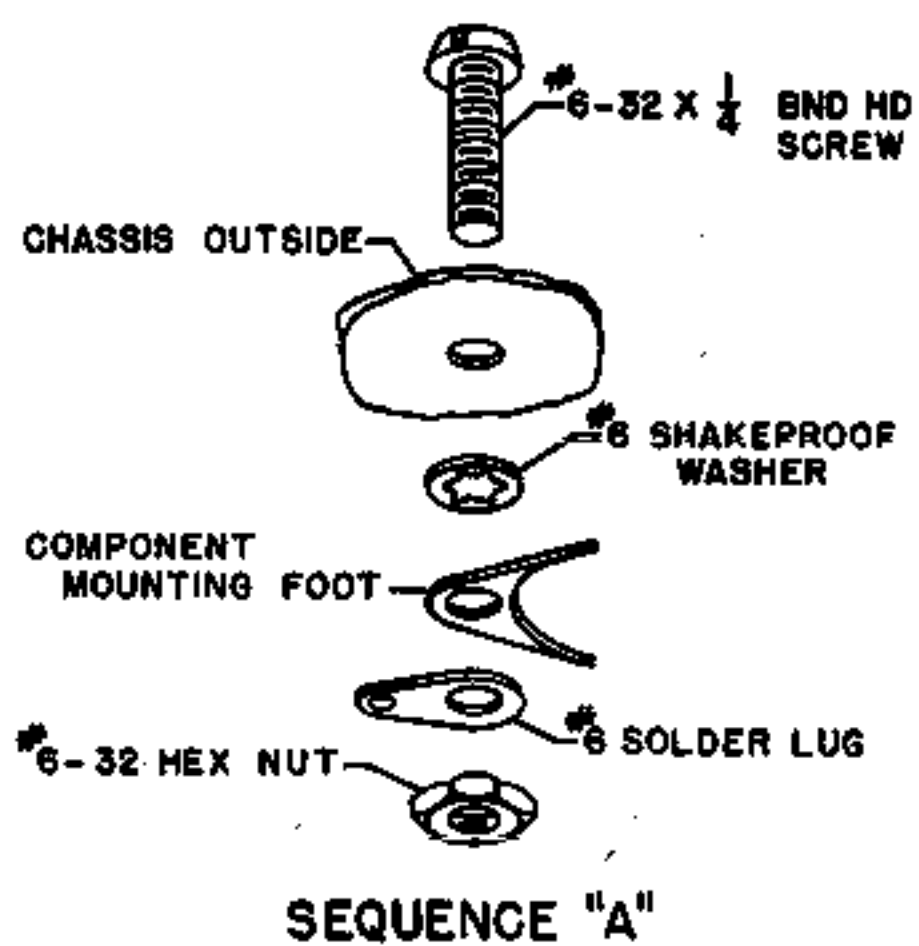

Hardware Sequence

VIKING RANGER II

Assembly Details

- A. **SOCKET, TERMINAL STRIP AND SMALL PARTS ATTACHMENT.** Refer to Figure 1, an unfolded view of the inside of the chassis, and the hardware sequence chart. Mount parts in order listed. Use the hardware described in the appropriate hardware sequence and in the order shown. Orient parts as shown in Figure 1. Temporary legs are attached in Part F. Do not attach any at this time.
1. () Mount XV6, 7 pin miniature socket, using hardware sequence D on inside mounting foot. Use hardware sequence E on the outside mounting foot.
 2. () Mount XV3, 9 pin miniature socket, using hardware sequence E.
 3. () Mount XV4, 9 pin miniature socket, using hardware sequence E.
 4. () Mount XV7, 9 pin miniature socket, using hardware sequence E.
 5. () Mount XV8, 9 pin miniature socket, using hardware sequence E.
 6. () Mount XV15, 9 pin miniature socket, using hardware sequence E and D.
 7. () Mount XV9, 8 pin octal socket, using hardware sequence B on the inside mounting foot. Use hardware sequence A on the outside mounting foot.
 8. () Mount XV10, 8 pin octal socket, using hardware sequence B on the inside mounting foot. Use hardware sequence A on the outside mounting foot.
 9. () Mount XV11, 8 pin octal socket, using hardware sequence B.
 10. () Mount XV12, 8 pin octal socket, using hardware sequence B on the inside mounting foot. Use hardware sequence A on the outside mounting foot.
 11. () Mount XV5, 8 pin octal socket, using hardware sequence A on the outside mounting foot. Mount TS30, a 3 lug terminal strip using hardware sequence B with the mounting foot of TS30 between the nut and socket mounting foot. Rotate TS30 180° from that position shown in Figure 1A.
 12. () Secure a #6 solder lug at each of the two holes provided behind and to the left of XV5. Use hardware sequence B.
 13. () Secure a #10 solder lug directly to the left of XV5. Use the following hardware sequence, inserting the screw from the top: 1/4" 6-32 binding head screw, chassis, #8 internal tooth lockwasher, #10 solder lug, #8 internal tooth lockwasher, 6-32 hex nut.
 14. () Secure two #6 solder lugs at the hole near the grommet and J4 holes shown in the upper right corner of Figure 1. Insert a 1/4" 4-40 screw at the rear, place a #4 shakeproof over the screw on the inside of the chassis, place two #6 solder lugs over the screw and secure tightly as shown with a 4-40 nut.
 15. () Mount TS15, 4 lug terminal strip, using hardware sequence A on outside mounting foot.
Mount TS16, 4 lug terminal strip, using hardware sequence B on both mounting feet.
 16. () Mount TS28, 5 lug terminal strip, using hardware sequence B.
 17. () Mount TS29, 5 lug terminal strip, using hardware sequence A.

- A. 18. () Mount TS20, 4 lug terminal strip using hardware sequence B on the outside mounting foot. Use hardware sequence A on the inside mounting foot.
19. () Mount TS24, 3 lug terminal strip, using hardware sequence B.
20. (✓) Mount TS25, 3 lug terminal strip, using hardware sequence B.
21. (✓) Mount TS26, 3 lug terminal strip, using hardware sequence B.
22. (✓) Mount TS18, 5 lug terminal strip, using hardware sequence B.
23. (✓) Mount TS19, 5 lug terminal strip, using hardware sequence A on the outside mounting foot. Use hardware sequence B on the inside mounting foot.
24. () Mount TS21, 5 lug terminal strip, using hardware sequence B.
25. (✓) Mount TS23, 5 lug terminal strip, using hardware sequence B on the outside. Use hardware sequence A on the inside with two #6 solder lugs.
26. (✓) Mount TS17, 6 lug terminal strip, using hardware sequence A on the inside mounting foot. Use hardware sequence B on the outside mounting foot.
27. () Mount TS22, 7 terminal strip, using hardware sequence A.
28. () Mount TS34, 8 terminal strip, using hardware sequence A on the outside mounting foot. Use hardware sequence B on the inside mounting foot.
29. (✓) Mount TS40, 2 lug terminal strip, using hardware sequence B.
30. () Place the six 9/16" O.D. rubber grommets in the holes designated G1-6.
31. () Place the one 11/32" O.D. rubber grommet in the hole designated G7.
32. (✓) Mount J1, the microphone receptacle, pin 2 should be toward the side of the chassis. Insert the 5/8" (terminal end) threaded bushing from the outside. Secure with the following hardware at the inside of the chassis: 5/8" internal tooth lockwasher, 5/8" hex nut.
33. (✓) Mount J2, the key jack, using hardware sequence G.
34. () Insert the 3/8" 8-32 round head screw, Gd, at the inside of the chassis and secure it with a #8 internal tooth lockwasher and an 8-32 nut and a #8 internal tooth lockwasher on the outside of the chassis.
35. (✓) Mount J3, the coaxial receptacle, using hardware sequence F inserting #6 solder lugs as shown.
36. (✓) Secure a #6 solder lug near J1 using the following hardware sequence from the outside of the chassis: 1/4" 4-40 screw, chassis, #4 internal tooth lockwasher, #6 solder lug, 4-40 hex nut.
37. () Mount J4, ceramic 2 terminal relay jack, using hardware sequence F.
38. () Mount R21, 1 megohm audio control (marked 22.832) using hardware sequence G.
39. () Mount D36, 37, 38, the three 2 15/16" 6-32 tapped aluminum spacers, using 1/4" 6-32 binding head screws and #6 internal tooth lockwashers. Refer to Figure 4A.
40. () Mount R13, the 25K ohm drive control (marked 22.732), using hardware sequence G.

- A. 41. () Mount SW2, the VFO-CRYSTAL switch, using hardware sequence G. Orient as shown in Figure 1A.
42. () Mount J5, the 8 pin octal crystal socket, as shown in Figure 1A. Attach 1 3/8" x 1/4" round spacers loosely to the top side of the octal socket mounting plate with 1/4" 6-32 binding head screws and internal tooth lockwashers. Hold the socket in position and attach the other ends of the spacer rods to the inside of the chassis with 1/4" 6-32 binding head screws and internal tooth lockwashers. Center the socket on the 1 1/2" chassis hole and tighten all screws securely.
- B. **BOTTOMSIDE CHASSIS GROUND CONNECTIONS.** Use #20 tinned wire, obtained by stripping the black hookup wire, on all connections in this part. Refer to Figure 1A and 4B.
- () Connect pin 5 of XV3 (NS), to the socket center shield (S), to pin 7 (NS), to ground lug near pin 6 (S).
 - () Connect pin 5 of XV4 (NS), to the socket center shield (S), to pin 7 (NS), to ground lug near pin 6 (S),
 - () Connect socket center shield of XV7 (S) to pin 9 (S) to ground lug near pin 9 (NS).
 - () Connect pin 4 of XV8 (S), to socket center shield (S), to pin 5 (S), to the ground lug near pin 6 (S).
 - () Connect pin 2 of XV6 (NS), to socket center shield (S), to pin 3 (S), to ground lug near pin 3 (NS).
 - () Connect pin 2 of XV9 (S), to ground lug near pin 2 (S).
 - () Connect pin 2 of XV10 (NS), to ground lug near pin 2 (S).
 - () Connect pin 2 of XV12 (S), to ground lug near pin 2 (S).
 - () Connect center shield of XV15 (NS) to pin 4 (NS), to ground lug (S) to pin 3 (S).
 - () Connect terminal 1 of TS15 (NS) to terminal 2 of TS15 (NS).
- C. **RF SECTION HARNESS INSTALLATION.** Refer to Figure 2. All leads have been cut to length and stripped.
- () Train the harness into position shown. Separate five leads, 46B, 34B, 30B, 39A and 35B, at the bend of the harness, and push all but the separated five through the rectangular cutout. Bend the leads over the inner front corner of the cutout to hold the harness in place.
 - () Separate three leads, 40B, 42B and 43B, at the end of the harness near TS19, and carefully push all but the three separated leads through the grommet G1.
 - () Make the harness connections on the bottom side of the chassis as indicated in Figure 2, with the exception of SW4 and SW5 leads which will be connected later. Train each lead near the harness or the chassis surface directly to the indicated terminal. A slight excess on any lead may be taken up with a slow U bend on the lead near the terminal. Hook the stripped lead ends into the terminals but do not solder at this time.
- D. **AUDIO SECTION HARNESS INSTALLATION.** Refer to Figure 3A. All leads have been cut to length and stripped.

- D.
1. () Train the harness into position as shown.
 2. () Push lead 12B, near TS19, through the grommet hole G1 with the leads from the other harness.
 3. () Make the audio section harness connections as indicated in Figure 3A, in the same manner as the RF section harness, with the exception of the shielded lead #13. Solder terminal 2 of TS23.
 4. () Make the shielded lead, 13B, connections in the following steps:
 - a. () Cut a 2 3/4" length from the end of 13B and save for a later connection.
 - b. () Cut another 3/4" length from the end of 13B, slip the shield braid off the insulation and place the 3/4" shield over R17, the 1 megohm, 1/2 watt resistor.
 - c. () Make certain 13B is brought out from the underside of the harness toward XV7. Lay the remaining 13B lead over pin 2 of XV7 and cut off any excess 1/4" beyond the pin.
 - d. () Remove 1/2" of braid and 3/8" of insulation from the end of 13B.
 - e. () Place the braid covered resistor, R17, along 13B as shown in Figure 3C. Loop a 1 1/2" piece of #20 wire around the ends of the braid of R17 and 13B. Solder the loop to the shield braids. Pull the braid over the lead on the opposite end of R17, solder the braid to the lead, and loop the lead around the 13B braid as shown in Figure 3C to hold R17 in place. Solder the loop and cut the excess lead wire.
 - f. () Hook the inner conductor of 13B over the lead of R17 near the resistor body. Solder quickly but thoroughly. Cut the R17 lead to 1/4" length and connect it to pin 2 of XV7 (S).
 - g. () Connect the grounding wire of R17-13B to the ground lug near pin 3 of XV7, (S), making the lead as short as possible.
 5. () Prepare 13A lead as follows:
 - a. () Push back the shield about 1/2" on the end of 13A.
 - b. () Cut off 1/4" insulation from the inner conductor.
 - c. () Wrap a 1 1/2" piece of bare #20 wire around the shield near the end of 13A.
 - d. () Solder the #20 lead to the shield and solder the other end of the bare lead to the ground lug near J1, the microphone jack. Keep this lead as short as possible.
 - e. () Solder the inner conductor to pin 1 of J1.

E. **TEMPORARY LEG ATTACHMENT, CONDENSER, SWITCH, AND RF CHOKE MOUNTING AND SWITCH CONNECTIONS.** Refer to Figures 4 and 5. If the switches have 3/8" nuts and internal tooth lockwashers as they are received, remove the nuts before starting the hardware sequence.

1. () Make four temporary legs per sketch, Figure 5F, from any conveniently available wood stock.
2. () Attach the legs to the chassis as shown in Figures 4A and 4B. Use 3/8" 10-24 thread forming screws.

- E. 3. () Mount C8, the dual section final variable capacitor in the following steps as shown in Figures 4A and 4B.
- a. () Place a 7/16" O.D. fiber shoulder washer over each of the three mounting holes (shoulder in the hole), and place C8 in position over the washers.
 - b. () Secure the capacitor only at the end mounting feet with the following hardware sequence: 3/8" 6-32 round head screw, #6 internal tooth lockwasher, 7/16" O.D. fiber shoulder washer (shoulder away from screw head), chassis, fiber washer, capacitor mounting foot.
 - c. () Mount SH1 as described in steps N11a, b and c.
4. () Mount SW3, the 4 section bandswitch, in the position shown in Figure 4B, in the following steps.
- a. () Place the hardware over the shaft as follows: 3/8" internal tooth lockwasher, 1 3/4" long by 1 1/2" wide L bracket with foot toward the switch section, 3/8-32 nut, VFO bandswitch drive arm, with the 1/8" pegs toward the switch section, a 3/8" threaded panel bushing over the shaft with the hex end toward the switch section, a 3/8" internal tooth lockwasher.
 - b. () Push the threaded bushing into the front chassis hole and secure it with a 3/8-32 nut.
 - c. () Hold the switch and brackets in position shown in Figure 4B and loosely secure the bracket between sections to the chassis at each of the mounting holes using the following hardware sequence: 1/4" 6-32 binding head screw, inserted at the top of the chassis, chassis, bracket, #6 internal tooth lockwasher, 6-32 hex nut.
 - d. () Secure the front bracket to the switch bushing with the 3/8"-32 nut, and loosely secure the bracket to the chassis with the same hardware used on the rear bracket. Push the switch toward the rear of the chassis and tighten all chassis-bracket screws securely.
5. () Mount the front brackets, meter switch, operate switch and VFO bandswitch.
- a. () Attach the four 1 3/8" long by 5/8" wide L brackets, BKT4-7, at the top front edge of the chassis as shown in Figure 4A. Use the following sequence: 3/8" 8-32 round head screw, bracket foot, chassis, #8 internal tooth lockwasher, #10 solder lug (only on BKT4 which supports SW5), 8-32 nut. The L brackets should be flush with front of chassis.
 - b. () Attach 3/8-32 panel bushings to the middle brackets using hardware sequence G.
 - c. () Mount SW5, phenolic meter switch as shown in Figure 5A using hardware sequence G.
 - d. () Mount SW4, operate switch, as shown in Figure 5B, using hardware sequence G.
 - e. () Mount SW1, VFO switch, on top of chassis in position as shown in Figure 5C. Use hardware sequence G.
- 6a. () Mount L6A as described in steps L24, 25 and 26.
 - 6b. () Mount L6B, the high frequency buffer coil, on the bottom side of the chassis. Orient in position as shown in Figure 4B. Form the #14 lead to allow it to pass through the 7/16" hole at the rear of L6B. Secure L6B at each insulator with a 1/4" 6-32 binding head screw and a #6 internal tooth lockwasher.

- E. 7. () Mount C7, the buffer variable capacitor, in position shown in Figure 4A. Space and secure the capacitor at each foot with the following sequence: 1/4" 6-32 binding head screw inserted from the bottom, #6 internal tooth lockwasher, chassis, two #8 flat-washers, capacitor foot. Mount TS39, a 2 terminal strip, near XV4 on the front mounting screw of C7 with the insulated terminal toward XV4.
8. () Make up and attach the final coil mounting stud at the hole near the rear mounting foot of the final capacitor as shown. Place a 2 1/2" 6-32 screw through the hole from the bottom, place a 2 1/16" long 1/4" dia. aluminum spacer, D35, over the screw and secure it with a #6 internal tooth lockwasher and a 6-32 hex nut.
9. () Mount R15, a 30,000 ohm 20 watt fixed screen dropping resistor below the chassis and the two lug terminal strip TS31, above the chassis. Use a 2 1/2" 6-32 screw, inserting it from the top with the following hardware and part sequence: screw head, terminal strip foot, chassis, 7/16" O.D. fiber shoulder washer, R15, 7/16" O.D. fiber shoulder washer, #6 internal tooth lockwasher, 6-32 hex nut.
10. () Attach the VFO switch driver arm and cam, D1 and D2, as directed in the following steps. Refer to Figure 7B.
- a. () Attach and tighten the 1 5/8" dial knob to the SW3 shaft with a 3/16" 10-32 setscrew.
 - b. () Push the VFO bandswitch drive arm, D1, toward the front of the chassis. Turn the VFO bandswitch, SW1, shaft to the middle (40 meter) position with a plier and the main bandswitch, SW3, shaft to the second position away from the counter-clockwise position (viewed from the front).
 - c. () Attach the drive cam, D2, to the end of the VFO switch shaft with a 3/16" 10-32 setscrew in the position shown in Figure 4B. Tighten the setscrew enough so that SW1 can be turned with D1.
 - d. () Orient the drive arm, D1, with the 1/8" dia. pins on the chassis side of the shaft, start two 3/16" #8 setscrews in the hub and push D1 toward D2 until the rear surface of D1 (surface toward D2) is just 5/16" from the front edge of D2. Rotate D1 counter-clockwise (viewed from front) in the 5/16" position until the left drive arm pin moves downward against the middle incline of D2. Back off so that the pin clears the incline by 1/64" to 1/32" and tighten the setscrews of D1 to hold it securely in position.
 - e. () Turn SW3 again to the counter-clockwise position (viewed from the front) and SW1 to the most counter-clockwise position (viewed looking into the bottom of the chassis).
 - f. () Test SW3 and SW1 action by turning the SW3 knob clockwise. As SW3 is turned from the counter-clockwise the band positions progress as follows, 160, 80, 40, 20, 15, 10 and 6. The VFO switch should turn 30° between 80 and 40 meter positions and between 10 and 6 meter position as the bandswitch knob is turned in either direction.
11. () Make necessary minor adjustments for good action and set the setscrews in place by loosening them slightly and retightening them very tightly. Figure 4B shows the switch cam-drive arm assembly as it should normally be in the 40 meter position. Although not necessary, a slight film of petroleum jelly or similar lubricant will help reduce friction.
12. () Make up the 3/8" coil fastener and core assembly for the oscillator coil, L5, as shown in Figure 1B. Push the four nut core into, and the fastener over the long unwound end of the 3/8" phenolic form of the coil, L5 as far as possible. Orient the coil so that the

- E. 12. terminals project as shown in Figure 1A and push the coil fastener hard into the chassis hole until the fastener tabs snap out on the topside of the chassis, holding the coil in place.
13. () Mount the 5 pi RF choke, L10, as shown in Figure 4A, with the terminals toward the front of the chassis. Use the following hardware sequence starting from bottom of chassis: 3/8" 8-32 round head screw, #8 internal tooth lockwasher, chassis, choke.
14. () Mount L37, 6 meter doubler coil as shown in Figure 1A. Assembly coil fastener E3 and core E4 to long unwound end of L37 and push in to chassis as in E12.
- F. POINT TO POINT CONNECTIONS. Using #20 green plastic covered wire, make the following point to point connections. Strip each end of the wire 5/16".
1. () Connect a 3" lead from pin 7 of XV9 (NS) to pin 7 of XV10 (NS).
 2. () Connect a 3" lead from pin 7 of XV9 (S) to pin 5 of XV15 (NS).
 3. () Connect a 5" lead from pin 7 of XV10 (S) to pin 4 of XV6 (S).
 4. () Connect a 5" lead from terminal 5 of TS17 (NS) to pin 2 of XV5 (NS).
 5. () Connect a 3" lead from terminal 4 of TS22 (NS) through grommet G2 to terminal 5 of TS34 (NS). TS22 is on top of the chassis.
 6. () Connect a 4" lead from pin 4 of XV3 (NS) to terminal 2 of TS34 (NS).
 7. () Connect a 3 1/4" lead from pin 7 of XV12 (NS) to terminal 5 of SW4B (NS).
- G. Using #20 black plastic covered wire, make the following point to point connections.
1. () Connect a 4" lead from pin 8 of XV9 (NS) to pin 8 of XV10 (S).
 2. () Connect a 4 1/4" lead from terminal 1 of TS17 (NS) along the chassis to the vicinity of R15 then to terminal 2 of R15 (NS).
 3. () Connect a 4 1/4" lead from terminal 2 of R15 (S) through grommet G7 to terminal 2 of TS31 (S).
 4. () Connect a 1 3/4" black lead from terminal 7 of TS22 (NS) through grommet G2 to terminal 4 of TS34 (NS).
 5. () Connect a 5 3/4" lead from terminal 6 of TS34 (NS) to terminal 11 of SW2 (S).
 6. () Connect a 6" lead from terminal 3 of TS15 (S) to terminal 10 of SW2 (S).
 7. () Connect a 2 1/2" lead from terminal 12 of SW2 (NS) to terminal 3 of R13, the drive control (S). Refer to Fig. 1A.
 8. () Connect a 4 1/2" lead from terminal 12 of SW2 (S) to the ground lug on XV3 nearest pin 8 (S).
 9. () Connect a 2 1/2" lead from pin 5 of J5 (S) to terminal 1 of SW2 (S).
 10. () Connect a 3 1/2" lead from pin 7 of J5 (S) to terminal 2 of SW2 (S).

G. 11. () Strip a 2" length and connect pins 1 and 3 of J5 (S) to ground lug near pin 1 of XV3 (S).

12. () Connect a 3 3/4" lead from terminal 6 of SW1 (S) to terminal 3 of TS22 (NS).

H. Using #20 yellow covered plastic wire, make the following connections.

1. () Connect a 3 1/2" lead from terminal 2 of TS22 (NS) to terminal 1 of TS34 (NS).

2. () Connect a 4 3/4" lead from pin 9 of XV3 (NS) to terminal 4 of SW2 (NS). Connect terminal 4 (S) to terminal 3 of SW2 (S) using bare #20 wire.

3. () Connect a 4 7/8" lead stripped 5/16" and 1/2" from terminal 3 of TS34 (NS) to terminals 5 and 6 of SW2 (S), the 1/2" end connecting 5 and 6. Train the lead under the harness.

4. () Connect a 8" lead from pin 7 of XV15 (NS) to terminal 4 of TS16 (NS).

I. Using #20 plastic covered wire, make the following point to point connections.

1. () Connect a 6 3/4" red lead from terminal 6 of TS22 (NS) to terminal 1 of TS15.

2. () Connect a 2 3/4" red lead from terminal 1 of TS40 (NS) to terminal 1 of L37 (NS). Keep this lead close to the chassis and orient it alongside terminals 1, 2, 3 and 4 of XV15. Refer to Fig. 8A.

3. () Connect a 3 1/2" orange lead from terminal 1 of TS22 (NS) and terminal 8 of TS34 (NS).

4. () Connect a 2" blue lead from terminal 1 of L5 (NS) to pin 6 of XV3 (S).

5. () Cut two leads, 4 1/2" blue, and 5 1/2" yellow. With one end of the wires even twist together three complete turns and make the following connections.

a. () The yellow lead, at the uneven length end of the twisted group to terminal 3 (NS) of L5.

b. () The blue lead of the twisted group to terminal 2 of L5 (S).

c. () Train the twisted group along the chassis to SW3A and untwist the ends only enough to make the connections of the next steps neatly.

d. () Connect blue lead to terminal 11 of SW3A (NS). Connect yellow lead to terminal 10 of SW3A (NS).

e. () Connect a 6 1/2" red lead from terminal 1 of TS15 (NS). Pass lead under harness. Connect other end to terminal 7 of SW3A front wafer (NS).

J. MISCELLANEOUS LEAD CONNECTIONS

1. () Make up the lead as shown in Figure 3B using the 2 3/4" length of shielded wire saved from step D4, making the following connections.

2. () The inner conductor of one end of pin 7 of XV7 (S) and the shield lead of that end to the ground lug near pin 9 of XV7 (NS).

3. () The inner conductor of the other end to terminal 2 of R21 the audio control (S) and the shield lead through terminal 1 (NS), then to the #10 solder lug on the chassis (NS).

4. () Make the harness connections to SW5, the meter switch. Refer to Figure 3A (lead 12B) and Figure 2 for lead connections and to Figure 5A for switch terminal locations. Pass

- J. 4. the leads between the front surface of the wafer and the index.
5. (→) Make the following additional connections to SW5:
- () Connect a 4" black lead from terminal 11 of SW5 (NS), thru the grommet G1 to the solder lug on the front foot of TS19 (NS).
 - () Connect a 1 1/2" black lead from terminal 11 of SW5 (S) to terminal 3 of SW5 (NS).
 - () Connect a 2 3/4" red lead to terminal 12 of SW5 (S). The other end will be connected later.
 - () Connect a 4" black lead to terminal 6 of SW5 (S). The other lead will be connected later.
 - (→) Connect a 2" black lead from terminal 3 of SW5 (S), to terminal 7 of SW5 (S).
6. () Make the harness connections to SW4, the operate switch. Refer to Figure 2 for lead connections and to Figure 5B for switch terminal connections. Connect the short leads first.
7. () Make the following additional connections to SW4:
- () Connect a 1 1/8" black lead from terminal 3 of SW4A (S) to terminal 5 of SW4A (S).
 - () Connect a 3/4" #20 tinned copper wire from terminal 9 of SW4A (S), to terminal 10 of SW4A (S).
 - (✓) Connect a 2 1/8" black lead from terminal 7 of SW4A (NS), to terminal 12 of SW4A (S).
 - () Connect a 1 1/8" black lead from terminal 3 of SW4B (NS) to terminal 5 of SW4B (S).
 - () Connect R47, .51 ohm 1/2 watt resistor, 1/2" leads from terminal 9 of SW4B (S) to terminal 12 of SW4B (S).
 - (✓) Connect a 1 1/2" black lead from terminal 7 of SW4A (S) to the solder lug on the front foot of TS15 (NS).

K. VFO ASSEMBLY, MOUNTING AND CONNECTIONS

- () Orient the phenolic plate, CH7, as shown in Figure 6A. Turn 9/16" 4-40 round head cadmium plated screws into the five holes A, B, C, D and E, the screws threading the plate as they are turned in. Turn A, B and C until the ends are flush with the opposite side of the plate. Turn D and E until they project 1/4" beyond the opposite side of the plate.
- () Secure the two miniature 7 pin sockets XV1 and XV2 on the sub-chassis plate CH8. Use hardware sequence H. Orient as shown.
- () Mount CH8 on CH7 as shown in Figure 6B, inserting the screws through the phenolic plate. Slide a #6 internal tooth lockwasher and a #6 solder terminal over one 7/8" 6-32 round head screw. Insert the screw into the CH8 mounting hole nearest the center of the phenolic plate, install a 1/2" spacer D24, the sub-chassis CH8, a #6 internal tooth lockwasher, and secure with a 6-32 nut.

- K. 3. Insert another 7/8" 6-32 screw into the mounting hole for CH8 furthest from the center of the chassis, install a 1/2" spacer, CH8 the sub-chassis, a #6 internal tooth lockwasher, two #6 solder terminals, secure with a 6-32 hex nut. Position solder terminals as shown and tighten.
4. () Place CH7 in position shown in Figure 6A. Connect a 3" length of #16 tinned wire to the solder terminal between sockets XV1 and XV2 (NS), loop the wire around terminal b (NS), and pass the free end through the hole near B and C.
5. () Connect C12, C13, C14 and C15, 500 volt silver mica capacitors as shown in Figure 6A as follows: (these capacitors are 2% tolerance).
- a. () Connect C12, 500 mmf, one lead to terminal A (NS), one lead to D (NS).
 - b. () Connect C13, 500 mmf, one lead to terminal B (NS), one lead to D (S).
 - c. () Connect C15, 1000 mmf, one lead to terminal B (NS), one lead to E (NS).
 - d. () Connect C14, 1000 mmf, one lead to terminal C (NS), one lead to E (S).

Cut, strip ends 5/16" and connect the following leads.

- 6. () Connect a 5 1/8" blue lead to terminal A (NS).
- 7. () Connect a 2" #20 bare lead to terminal A (S).
- 8. () Connect a 5 1/8" red lead to terminal C (NS).
- 9. () Connect a 2" #20 bare lead to terminal C (S).
- 10. () Pass the free end of the blue lead through the hole near D and the free end of the red lead through the hole near E.

Mount and secure the following miniature trimmer capacitors to the phenolic board CH7 as follows: See Figures 6A and 6B.

- 11. () Mount C2, 15M11 capacitor with a left rotor terminal (viewed from the rear with the stator terminal pointing down).
- 12. () Mount C3, 30M8 capacitor with a right rotor terminal.
- 13. () Mount C4, 15M11 capacitor with a right rotor terminal. Place a #10 solder terminal on each side of the phenolic board while mounting C4.
- 14. () Mount C5, 15M11 capacitor with a left rotor terminal. Place a #10 solder terminal on the top side of the phenolic board while mounting C5 as shown in Figure 6A.
- 15. () Mount C6, 30M8 capacitor with a right rotor terminal.
- 16. () Cut a 3" length of #16 tinned wire. Hook one end into the two #10 solder terminals between C4 and C5 (S). Connect the other end to terminal B (NS).

Cut the following lengths of plastic insulated wire, strip the ends 5/16" connect one end of each as follows, refer to Figure 6B.

- 17. () Connect a 3 1/4" green lead to the stator terminal of C3 (NS). Pass the free end through the large hole near C2 in the phenolic plate.
- 18. () Connect a 2 3/4" green lead to the stator terminal of C3 (NS).

- K. 19. () Connect a 3 1/4" black lead to the stator terminal of C4 (NS).
20. () Connect a 4 1/2" yellow lead to terminal D on the phenolic board (S).
21. () Connect a 4" green lead to terminal E on the phenolic board (S).
22. () Connect a 2 3/4" yellow lead to the stator terminal of C6 (NS). Pass the free end through the hole in the phenolic plate near the C6 rotor terminal.
23. () Fasten four 3/8" x 7/8" aluminum brackets, BKT8 through BKT11, to the mounting posts of C1, the two section variable capacitor. Secure with 1/4" 6-32 binding head screws, and #6 internal tooth lockwashers as shown in Figure 6B. Level the bracket feet on a flat surface while tightening the screws.
- 23a. () Identify C100, the differential capacitor, mounting bracket BKT13. Using BKT13, mount C100, 19M11 variable capacitor, on the bracket, BKT13, with hardware furnished with the capacitor as in Figure 6A.
24. () Place C1 in position on the phenolic plate CH7 and secure BKT10 to CH7 with 3/8" 6-32 round head screws, #6 internal tooth lockwashers, and 6-32 hex nuts. Using the above hardware sequence, place the screw thru the mounting hole in BKT13 from the inside, then thru the hole at BKT8 from the top of CH7, then thru BKT8. Position BKT13 so the bracket is parallel with the front edge of CH7 as in Figure 6A. Do not secure BKT9 and BKT11 at this time.
25. () Install D34, flexible disc coupling to C1. Start all four 3/16" 8-32 setscrews. Turn C1 shaft counter-clockwise to the stop. Slide D34 over the end of the shaft to within 1/16" of the bushing of C1. Position D34 so that when viewed from the shaft end of C1 with C1 right side up the front setscrews of D34 are up and to the left. Tighten setscrews on C1 shaft.

Make the following connections with stripped black #20 hookup wire as directly as possible unless training the lead is specified.

26. () Connect a 1 1/4" lead between C6 rotor (S) and C1B stator terminals (NS).
27. () Connect a 1" lead between C6 stator (NS) and C5 stator terminals (S).
28. () Connect a 1 1/4" lead between C5 rotor (S) and C4 rotor terminals (NS) then to the #10 solder terminal of C4 (S).
29. () Connect a 1 1/4" lead between C3 rotor (S) and C1A stator terminals (NS).
30. () Connect a 2" lead between C2 and C1 rotor terminals. Run the lead directly from the C2 rotor terminal (S) to the phenolic plate to a position in line with the rotor terminal of C1 (NS).
31. () Connect a 1 1/4" lead between C2 stator (S) and C3 stator terminals (NS).
- 31a. () Connect a 1 1/2" lead between C100 rotor (S), and the solder lug between XV1 and XV2 (S).
- 31b. () Connect one lead of C91, a 22 mmf. dipped mica capacitor, to the rotor terminal of C4 (S), the other lead to the stator terminal of C4 (S).
32. () Cut one lead of C11, a 62 mmf NPO ceramic tubular capacitor (black-blue-red-black-orange) to 5/8", the other lead to 3/8". Place the capacitors in the position shown in Figure 6B. Connect the 3/8" lead to the stator terminal of C3 (S), the 5/8" lead to the stator terminal of C1A (S).

- K. 33. () Cut one lead of C17, a 140 mmf NPO ceramic tubular capacitor (black-brown-yellow-brown-orange) to 3/4", the other lead to 3/8". Place in the position shown in Figure 6B. Connect the 3/8" lead to the stator terminal of C6 (S) and the 3/4" lead to the stator terminal of C1B (S).
34. () Connect the #16 wire extending through the hole between C2 and C1 to the rotor terminal of C1. Train the lead directly to the terminal and pass the end through it (S).
35. () Attach the four 2 1/8" and four 2 15/16" spacer rods at the corners of the phenolic plate, CH7, with the 5/8" 6-32 threaded studs. Place the 2 15/16" spacers on the bottom side of the phenolic plate shown in Figure 6B, and the 2 1/8" spacers on the top side of the phenolic plate, shown in Figure 6A.
36. () Using a 2" piece of stripped #20 hookup wire, connect pins 2 (S), 3 (S) and the center shield of XV1 (S) to the nearest ground terminal (NS).
37. () Cut a 3 3/4" length of #16 tinned bare wire. Pass one end through pin 7 of XV2 to the nearest sub-chassis ground terminal (S). Also solder at pin 7, leave the extra length for later connection when the VFO is mounted.
38. () Cut the leads of R1, 100K ohms 1/2 watt resistor, to 1". Connect one lead to pin 1 of XV1 (NS). Train the resistor straight away from the socket for a later connection.
39. () Cut the leads of C19, .005 mfd. ceramic disc capacitor, to 1/2". Connect one lead to pin 6 of XV1, (NS), the other lead to the sub-chassis ground terminal remaining unsoldered (S).

40. () Connect a 1 1/4" blue lead between pin 6 of XV1 (S) and pin 5 of XV2 (S).

41. () Cut one lead of R3, 18K ohms 2 watt resistor, to 3/8" length, the other lead to 3/4". Connect the 3/8" lead to pin 1 of XV2 (S). The 3/4" lead will be connected later.

Cut the following lengths of plastic insulated hookup wire, strip the ends 5/16", connect one end of each as follows:

42. () Connect a 2" green lead to pin 4 of XV1 (S).

43. () Connect a 2" black lead to pin 7 of XV1 (S).

44. () Connect a 2 1/2" red lead to pin 5 of XV1 (S).

45. () Twist the blue and yellow leads (near C4) together two complete turns, twist red and green leads (near C5) together two complete turns.

46. () Attach the 2" 6-32 screws to the VFO coil L1 (shown in Figure 7A) inserting the screws in the coil form from the side opposite the terminals so the following hardware sequence results: 2" screw head, internal tooth lockwasher, coil form walls, 7/16" fiber shoulder washer (shoulder toward the coil form), 6-32 nut. Tighten the nuts securely but do not turn the nut as far as possible with pliers or a wrench as the form can be broken with such treatment. Place another nut on each screw and turn the nuts down tight to jam the securing nut.

47. () Turn another 6-32 nut on each mounting screw of L1 until 5/16" of screw thread projects beyond the nut. Mount the coil on top of CH7 (see Figure 7A) in the holes above BKT9 and BKT11. The space wound coil should be above C1B, toward the front edge of CH7. Secure each of the mounting screws of L1 and the brackets of C1 to CH7 with #6 internal tooth lockwashers and 6-32 hex nuts.

- K. 48. () Connect the terminal of L1 nearest the front of CH7, #20 lead from terminal A of CH7 to terminal 4 of L1 (S).
49. () Connect the green lead emerging through the hole near terminal B of CH7 to terminal 3 of L1 (NS).
50. () Connect the tinned #20 lead from terminal C of CH7 to terminal 2 of L1 (S).
51. () Connect the yellow lead emerging through the hole near C6 to terminal 1 of L1 (NS).
52. () Connect one lead of C10, A and B, 30 mmf N150 ceramic disc capacitor, (this capacitor is made of a 15 mmf N330 and a 18 mmf NPO assembly per sketch) to terminal 3 of L1 (NS) (previously connected a green lead to this terminal), the other lead to the screwhead slot of terminal screw B (S). Keep leads as short as possible.
- 52a. () Connect one lead of C98, 12 mmf NPO ceramic disc capacitor, to the right stator terminal of C100 (S), the other lead to terminal 3 of L1 (NS). Keep leads as short as possible.
- 52b. () Connect one lead of C99, 12 mmf N750 ceramic disc capacitor, to the left stator terminal of C100 (S), the other lead to terminal 3 of L1 (S). Keep leads as short as possible.
53. () Cut the leads of C16, 91 mmf N080 tubular ceramic capacitor (red-white-brown-black-orange), one to 5/8" the other to 1". Connect the 5/8" lead to terminal 1 of L1 (S). Adjust the position of C16 so that it is parallel to the axis of L1 and connect the 1" lead to the #16 ground wire at the point where a line between terminals D and E of CH7 would cross the #16 wire (S).
54. () Make the following connections at the VFO terminal strip, TS22, and the VFO band-switch SW1, on the top side of the transmitter chassis.
55. () Connect one lead of C20, .005 mfd ceramic disc capacitor, to terminal 7 of TS22 (NS), the other lead to the outside ground terminal of TS22 (NS).
56. () Connect one lead of C21, .005 ceramic disc capacitor, to terminal 4 of TS22 (NS) the other lead to the inside ground terminal of TS22 (NS).
57. () Connect one lead of C26, .005 mfd ceramic disc capacitor, to terminal 5 of TS22 (NS), the other lead to the outside ground terminal of TS22 (NS).
58. () Connect R5, 470 ohm 1/2 watt, between terminals 5 (NS) and 6 (NS) of TS22.
59. () Connect R6, 22,000 ohm 1/2 watt resistor between terminal 2 of TS22 (NS) and terminal 5 of TS22 (NS).
60. () Connect one lead of L3, 2.4 MH 4 pi RF choke, to terminal 3 of TS22 (NS) and the other lead to terminal 7 of TS22 (S).
61. () Connect L2, 52 uh the green single pi RF choke, between terminal 2 of TS22 (NS) and terminal 9 of SW1 (NS). Train L2 just above SW1 to TS22.
62. () Connect a 3 1/4" black lead from terminal 5 of TS22 (S) and terminal 10 of SW1 (NS).
63. () Connect a 1" black lead from terminal 10 of SW1 (S) to terminal 8 of SW1 (NS).
64. () Connect R4, 1500 ohm 1 watt resistor, from terminal 9 of SW1 (S) to terminal 8 of SW1 (S).

- K. 65. () Connect one lead of C86, 500 mmf. molded mica capacitor to terminal 1 of TS22 (NS) the other lead to the inside ground terminal of TS22 (S).
66. () Cut one lead of C18, 43 mmf. NPO tubular ceramic capacitor (black-yellow-orange-black-orange) and one lead of R2, 56 ohm 1/2 watt resistor, both to 3/8" long. Hook these ends together and solder. Connect the remaining lead of C18 to terminal 2 of SW1 (S). Bend the assembly over toward TS22.
67. () Mount the VFO in position as shown in Figure 7A, secure it to the chassis using 1/4" x 6-32 binding head screws and #6 internal tooth lockwashers.
68. () Connect the remaining lead of R2 (see operation K66) to terminal 1 of XV1 (S). Leave enough slack to clear other components.

Connect the leads between the VFO and main chassis as follows:

69. () Connect the red (twisted) lead to terminal 1 of SW1 (S).
70. () Connect the green lead (from C3) to terminal 12 of SW1 (S).
71. () Connect the black lead (from C4) to terminal 11 of SW1 (S).
72. () Connect the blue (twisted) lead to terminal 3 of SW1 (S).
73. () Connect the green (twisted) lead to terminal 5 of SW1 (S).
74. () Connect the yellow (twisted) lead to terminal 7 of SW1 (S).

Make the following connections from sockets XV1 and XV2 to terminal strip TS22.

75. () Connect the remaining lead of R3, 18K ohms 2 watt resistor to terminal 6 of TS22 (S).
76. () Connect the red lead to terminal 2 of TS22 (S).
77. () Connect the black lead to terminal 3 of TS22 (S).
78. () Connect the green lead to terminal 4 of TS22 (S).
79. () Connect the #16 tinned lead to the outside ground terminal of TS22 (S).
80. () Connect the remaining lead of R1, 100K ohm 1/2 watt resistor, to terminal 1 of TS22 (S).

L. RF EXCITER COMPONENT CONNECTIONS. Refer to Figure 7B and 11.

1. () Connect L15, 100 uh choke, (large red) from terminal 2 of TS34 (S) and terminal 5 of TS34 (S).
2. () Connect L16, 200 uh choke, (red) from terminal 4 of TS34 (S) to terminal 6 of TS34 (S).
3. () Connect C22, 300 mmf mica capacitor from terminal 1 of TS34 (S) to terminal 3 of TS34 (S).
4. () Connect R7, 100,000 ohm 1/2 watt resistor, from pin 9 of XV3 (NS) and terminal 7 of TS34 (NS).
5. () Connect C87, .005 mfd. disc ceramic capacitor, from terminal 7 of TS34 (S) to the ground solder terminal of TS34.
6. () Connect C27, .005 mfd. disc ceramic capacitor, from pin 7 of XV3 (S) to pin 8 of XV3 (S).

- L. 7. () Connect C25, .005 mfd. disc ceramic capacitor, from pin 4 of XV3 (S) to pin 5 of XV3 (S).
- 7a. () Connect C28, .005 mfd. disc ceramic capacitor, from terminal 1 of TS15 (NS) to ground lug of XV3 (S) near pin 4.
8. () Connect C23, 25 mmf. silver mica capacitor, from pin 9 of XV3 (S) to terminal 7 of SW2 (S).
9. () Connect R8, 68,000 ohm 1/2 watt resistor, from pin 3 of XV3 (S) to terminal 1 of TS15 (NS) then to terminal 2 of TS15 (NS).
10. () Connect R25, 3 ohm, 1/2 watt resistor, from terminal 4 of TS15 (NS) and the solder terminal on the front mounting foot of TS15.
11. () Connect C30, .005 mfd. disc ceramic capacitor, from terminal 4 of TS15 (NS) to front ground solder terminal (S).
12. () Cut the leads of C24, a 200 mmf. mica capacitor to 1/2" length. Connect and solder C24 across the leads of L4, a 4 pi RF choke, spacing the flat side of C24 1/8" from the pies of L4.
13. () Connect L4-C24 combination from pin 1 of XV3 (S) to terminal 4 of TS15 (S).
14. () Connect C31, .005 mfd. disc ceramic capacitor from pin 4 of XV4 (S) to pin 5 of XV4 (S).
15. () Connect C34, .005 mfd. disc ceramic capacitor from pin 1 of XV4 (NS) to the ground lug near pin 3 of XV4 (S).
16. () Connect C33, .005 mfd. disc ceramic capacitor from pin 7 of XV4 (S) to pin 8 of XV4 (S).
17. () Connect R11, 100,000 ohm 1/2 watt resistor, from pin 9 of XV4 (NS) to terminal 2 of TS39 (NS).
18. () Connect C88, .005 disc ceramic capacitor, from terminal 2 of TS39 (NS) to terminal 1 of TS39 (S).
19. () Connect C29, 50 mmf. mica capacitor, from terminal 1 of L5 (NS) to pin 9 of XV4 (S). Place C29 on edge against the chassis.
20. () Connect R10, 33,000 ohm 1/2 watt resistor, from terminal 1 of L5 (S) to terminal 3 of L5 (S).
- 21a. () Connect R26, 3 ohm 1/2 watt resistor, from pin 1 of XV4 (S) to terminal 1 of TS16 (NS).
- 21b. () Connect R9, 470 ohm 1/2 watt resistor, from term. 3 of TS16(NS) to term. 4 of TS16(S).
22. () Connect R12, 470 ohm 1/2 watt resistor, from terminal 1 of TS16 (S) to terminal 3 of TS16 (S).
23. () Connect a 2 3/4" black lead to pin 6 of XV4 (S) and to terminal 2 of L6B, the high frequency buffer coil (NS).
24. () Identify L6A, the low frequency buffer coil, from Figure 1C. Attach the mounting screws using the following hardware sequence: 1 3/8" 6-32 round head screw, #6 spade lug, 7/16" OD fiber shoulder washer with shoulder toward the coil form. Insert the screw from the terminal side, next install a fiber shoulder washer, #6 spade lug, a #6 internal tooth lockwasher and a 6-32 hex nut. Tighten securely, taking care not to break the coil form.

- L. 25. () Connect #20 plastic hookup wire leads to the taps of L6A as follows:
- a. () Green 3 3/4" length to terminal 1 of L6A (bottom terminal) (S). Train this lead and the following leads directly toward the spade lug end of L6A.
 - b. () Red, 4" to terminal 2 of L6A (S).
 - c. () Yellow, 3 3/4" to terminal 3 of L6A (S).
 - d. () Blue, 3 1/2" to terminal 4 of L6A (S).
 - e. () Black, 5" to terminal 5 (top terminal) of L6A (NS).
26. () Mount L6A on the top of the chassis as shown in Figure 11. Place the leads through the grommet G5 while putting the coil in position and train the leads toward the rear terminals of the front bandswitch wafer SW3A. Secure L6A with #6 internal tooth lockwashers and 6-32 nuts.
27. () Make the following connections to the front bandswitch wafer; SW3A, (refer to Figure 5E for terminal numbering and Figure 7B for component location).
28. () Connect L12, 200 uh RF choke, (coded red) from terminal 7 (front) of SW3A (NS) to terminal 1 (rear) (NS).
29. () Connect C36, .005 mfd. disc ceramic capacitor, from terminal 1 (rear) of SW3A (NS) to a #6 solder terminal (loose) (S) for later mounting.
30. () Connect the black lead from L6A to terminal 1 (rear) of SW3A (S).
31. () Connect the blue lead from L6A to terminal 2 (rear) of SW3A (S).
32. () Connect the yellow lead from L6A to terminal 3 (rear) of SW3A (S).
33. () Connect red lead from L6A to terminal 4 (rear) of SW3A (S).
34. () Connect green lead from L6A to terminal 5 (rear) of SW3A (NS).
35. () Connect the #20 lead from terminal 1 of L6B (high frequency buffer coil) to terminal 5 (rear) of SW3A (S). Train as directly as possible and bending the lead to clear the switch shaft by 1/8".
36. () Connect the #20 lead from the top of L6B to terminal 6 (rear) of SW3A (S). Bend enough to clear the switch shaft support rod.
37. () Connect L36, 19 turns of #18 formex wire wound on 3/8" dowel rod, from terminal 12 (front) of SW3A (S) to terminal 11 (front of SW3A) (S).
38. () Connect L27, 2.4 mh RF choke, from terminal 7 (front) of SW3A (S) to terminal 10 (S) to terminal 9 (S), to terminal 8 (S) of SW3A front.
39. () Connect the #14 lead from L6B to the rear stator terminal of C7. Train the lead through the center of the chassis hole, push the end through the stator terminal (S).
40. () Connect C35, a 10 mmf. silver mica capacitor from the free stator terminal of C7 (S) to the rotor terminal of C7 (NS).
41. () Connect a 4 1/4" length of black wire from the rotor terminal of C7 (S) to the ground terminal of XV4 (S) near pin 1 of XV4. Pass the lead through the same hole as the #14 lead of L6B. Train along the chassis away from the #14 lead.

M. AUDIO SECTION COMPONENT MOUNTING AND CONNECTIONS. Refer to Figure 8A and 11 for component identification and to Figure 1A for terminal identification.

1. () Mount the modulation transformer, T2, (marked SNC P2429), and the 10-10 mfd electrolytic capacitors C50A, C50B, as follows:
 - a. () Cut the modulation transformer, T2, leads to lengths listed below (unless it is supplied near the lengths given). Strip 3/8" and tin the ends.
 1. () Red - 5 1/4"
 2. () Blue - 5 3/4"
 3. () Brown - 5 1/4"
 4. () White - 5"
 5. () Black-White - 4 3/4"
 6. () Yellow - 6"
 7. () Green - 5 3/4"
 8. () Black - 5 3/4"
2. () Mount T2 and C50 in position shown with the side of T2 which includes the red lead toward the middle of the chassis, the mounting strap of C50 toward the front. Pull the leads of T2 through the grommets. Secure at each foot with the following hardware, starting from the top of the chassis: 3/8" 8-32 screw head, #8 internal tooth lockwasher, mounting foot, chassis, C50 strap, #8 internal tooth lockwasher, 8-32 hex nut.
3. () Connect the negative lead of C50 to the solder terminal at the securing nut of SW5 (S). Bend C50 into position as shown in Figure 8A.
4. () Twist the red, blue and brown leads of T2 together two turns. Train the leads along the chassis between XV9 and XV10 and connect the leads as follows.
 - a. () Blue to pin 3 of XV9 (S).
 - b. () Brown to pin 3 of XV10 (S).
 - c. () Red to terminal 1 of TS21 (NS).
5. () Twist the green, yellow and black leads together two turns. Train the leads along the bend of the chassis and connect them as follows:
 - a. () Yellow to terminal 5 of TS18 (NS).
 - b. () Black to terminal 3 of TS18 (S).
 - c. () Green to terminal 1 of TS18 (NS).
6. () Train the white and black-white leads along the chassis to TS20 and connect them as follows:
 - a. () White to the solder terminal on the rear of TS20 (NS).
 - b. () Black-white to terminal 3 of TS20 (NS).
7. () Connect R22, 4700 ohm 1/2 watt resistor, from pin 8 of XV7 (NS) to ground terminal (S) near pin 6 of XV7.
8. () Connect R18, 4700 ohm 1/2 watt resistor, from pin 3 of XV7 (NS) to ground terminal (S) near pin 1 of XV7.

- M. 9. () Connect C56, 470 mmf. dipped mica capacitor from pin 6 of XV7 (NS) to center ground terminal of XV7 (NS).
10. () Connect C54, .01 mfd. disc ceramic capacitor, from pin 3 of XV7 (NS) to ground terminal in the center of XV7 (S).
11. () Connect C53, 200 mmf. mica capacitor from terminal 1 of R21, audio control (S) to terminal 3 of R21 (NS).
12. () Connect the front positive lead of C50 to pin 8 of XV7 (NS).
13. () Connect the rear positive lead of C50 to pin 3 of XV7 (NS).
14. () Connect C52, 500 mmf. mica capacitor from terminal 3 of R21 (S) to pin 1 of XV7 (NS).
15. () Connect R19, 470,000 ohm 1/2 watt resistor, from terminal 2 of TS19 (NS) to pin 1 of XV7 (S).
16. () Connect C51, .1 mfd. tubular paper capacitor, from terminal 2 of TS19 (NS) to ground lug (NS) near pin 8 of XV8. Connect the banded end to ground lug.
17. () Connect R20, 220,000 ohm 1/2 watt resistor, from terminal 1 of TS19 (NS) to terminal 2 of TS19 (S).
18. () Connect R24, 47,000 ohm 1/2 watt resistor, from terminal 1 of TS19 (NS) to terminal 3 of TS19 (NS).
19. () Connect C73, .005 mfd. disc ceramic capacitor, from terminal 5 of TS19 (S) and the solder lug at the front of TS19 (S).
20. () Connect C55, .1 mfd. tubular paper capacitor, from terminal 3 of TS19 (NS) to the solder terminal at the rear of TS20 (S). Connect the banded end to the ground lug.
21. () Connect R28, 820 ohm 1/2 watt resistor, from pin 3 of XV8 (NS) and the ground terminal near pin 1 of XV8 (S).
22. () Connect C70, .005 mfd. disc ceramic capacitor, from pin 9 of XV8 (S) to ground lug near pin 8 (S).
23. () Connect R27, 150,000 ohm 1/2 watt resistor, from pin 2 of XV8 (NS) to terminal 3 of TS20 (S).
24. () Mount C59, dual 15 mfd. 150 volt electrolytic capacitor, in the hole on the side edge of the chassis above XV10 with the strap toward the top of the chassis. Use hardware sequence B. The blue and black leads should be to the front of the chassis.
25. () Cut the black and green leads to 3" length. Strip and tin 5/16". Connect to pin 2 of XV10 (NS).
26. () Connect the blue lead to terminal 4 of TS20 (NS). Route along the chassis.
27. () Connect the red lead to pin 3 of XV8 (NS).
28. () Connect R23, 470,000 ohm 1/2 watt resistor, from pin 6 of XV7 (NS) to terminal 3 of TS19 (S).
- 29a. () Connect C57, .02 mfd. 400 volt, paper tubular capacitor, from pin 6 of XV7 (S) to pin 7 of XV8 (NS).
- 29b. () Install C58 and C101 as described in steps M68 and M69.

- M. 30. () Connect a 1" yellow lead from pin 2 of XV8 (S) to pin 7 of XV8 (S).
31. () Connect a 1 1/8" black lead from pin 3 of XV8 (S) and pin 8 of XV8 (S).
32. () Connect a 1 1/4" blue lead from pin 1 of XV8 (S) to pin 6 of XV8 (NS).
33. () Connect C71, .1 mfd. paper tubular capacitor, from pin 2 of XV10 (S) to terminal 3 of TS21 (NS). The band end goes to pin 2 of XV10.
34. () Connect a 1 1/2" black lead from pin 8 of XV9 (S) to terminal 1 of TS20 (NS).
35. () Connect R48, .51 ohm 1/2 watt resistor, from terminal 1 of TS20 (S) to ground terminal on TS40 (NS).
36. () Connect R30, 100 ohm 1/2 watt resistor, from pin 4 of XV9 (S) to terminal 3 of TS21 (NS).
37. () Connect R31, 100 ohm 1/2 watt resistor, from pin 4 of XV10 (S) to terminal 3 of TS21 (S).
38. () Connect C60, .005 mfd. 400 volt paper tubular capacitor, from terminal 2 of TS21 (NS) to terminal 4 of TS21 (NS).
39. () Connect R32, 100 ohm 1/2 watt resistor, from pin 5 of XV9 (S) to terminal 2 of TS21(NS).
40. () Connect R33, 100 ohm 1/2 watt resistor, from pin 5 of XV10 (S) to terminal 4 of TS21 (NS).
41. () Connect C85, .005 mfd. disc ceramic capacitor, from pin 6 of XV6 (NS) to center shield of XV6 (S).
42. () Make up and connect R36, 3, 33,000 1 watt connected in parallel, from pin 6 of XV6 (S) to terminal 5 of TS21 (S).
43. () Connect C69, .02 mfd. 1600 volt tubular, from terminal 1 of TS18 (S) to terminal 5 of TS18 (S). Orient as shown in Figure 8A.
44. a. () Connect C95, .005 mfd. disc ceramic capacitor, from terminal 1 of L37 (NS) to ground terminal (S) of XV15.
- b. () Connect C102, .005 mfd. disc ceramic capacitor from terminal 1 of L37 (S) to pin 7 of XV15 (S).
45. () Connect C97, 27 mmf. dipped mica capacitor, from terminal 2 of L37 (NS) to terminal 3 (rear) of SW3B (S).
46. () Connect a 1 1/4" bare lead from terminal 2 of L37 (S) to pin 1 of XV15 (S).
47. () Connect 2 1/2" green lead from pins 8 (NS), and 9 (S) of XV15 to terminal 1 (front) SW3B (S).
48. () Connect R56, 100,000 ohm 1/2 watt resistor, from pin 8 of XV15 (S) to ground terminal of XV15 (NS) near pin 6.
49. () Connect C94, .01 mfd. disc ceramic capacitor, from pin 7 of XV15 (S) to ground terminal of XV15 (S) near pin 6.
50. () Connect C92, .01 mfd. ceramic disc capacitor, from terminal 1 of TS40 (NS) to terminal 2 of TS40 (S).
51. () Connect C96, .005 mfd. disc ceramic capacitor, from pin 4 of XV15 (S) to pin 5 of XV15 (S).

- M. 52. () Connect R46, 10,000 ohm 1 watt resistor, from terminal 1 of TS40 (S) to terminal 6 of XV15 (NS).
53. () Connect C93, .01 mfd. disc ceramic capacitor, from pin 6 of XV15 (S) to center shield of XV15 (S).
54. () Using #20 bare tinned copper wire connect terminal 7 of SW3B (NS) to terminal 8 of SW3B (S) to terminal 9 of SW3B (S) to terminal 10 of SW3B (NS) to terminal 11 of SW3B (S) to terminal 12 of SW3B (S).
55. () Connect a 1 3/8" orange lead from terminal 10 of SW3B (S) to terminal 3 of TS30 (NS).
56. () Connect a 2 1/4" orange lead from terminal 1 of TS30 (NS) to terminal 6 of SW3B (S).
57. () Connect a 2" orange lead from terminal 7 of SW3B (S) to terminal 4 of SW3B (S).
58. () Connect C72, .005 mfd. disc ceramic capacitor, from terminal 1 of J2 (S) to terminal 2 of J2 (NS).
59. () Connect L14, 4.7 uh RF choke, from terminal 2 of J2 (S) to terminal 1 of TS26 (S).
60. () Mount and connect the driver transformer, T3, (marked P1503), as shown in Figure 8A as follows:
- a. () Cut the leads to the indicated lengths, strip 5/16" and tin ends as listed.
- | | | | |
|----|-----|--------|--------|
| 1. | () | Red | 6 1/2" |
| 2. | () | Blue | 4 1/2" |
| 3. | () | Yellow | 5" |
| 4. | () | Green | 5" |
| 5. | () | Black | 7" |
61. () Mount T3 in position, red and blue leads toward the front of the chassis and secure (starting at the foot near the chassis top with the following hardware, starting inside the chassis: 1/4" binding head screw, #6 internal tooth lockwasher, #6 solder terminal (only at the foot near the chassis lip) T3 foot, chassis, #6 internal tooth lockwasher, 6-32 hex nut.
62. () Connect the black lead to terminal 4 of TS20 (S).
63. () Connect the blue lead to pin 6 of XV8 (S).
64. () Connect the red lead to terminal 1 of TS19 (S). Train lead directly along the chassis.
65. () Twist the green and yellow leads together 2 1/2 turns.
66. () Connect the green lead to terminal 2 of TS21 (S).
67. () Connect the yellow lead to terminal 4 of TS21 (S).
68. () Connect C58, a 330 mmf dipped mica capacitor, from pin 2 of XV7 (S) to pin 3 of XV7 (S).
69. () Connect C101, a 82 mmf dipped mica capacitor, from pin 7 of XV7 (S) to pin 8 of XV7 (S).
- N. FINAL TANK, COUPLING CIRCUIT, HV CHOKE MOUNTING AND CONNECTIONS. Refer to Figures 8B and 8C.
1. () Make up C39A and C39B, 300 mmf. silver mica capacitors. Cut leads of C39B to 3/8" and

- N. 1. 7/8". Cut the leads of C39A to 3/8" and 1 3/8". Form hooks on the 3/8" leads, hook them together, crimp and solder them.
2. () Connect the 7/8" lead to the left front stator (rear view, of C8B, (S)). Connect the 1 3/8" lead to the rotor terminal at the rear of C8 (NS).
3. () Mount the insulated solder terminals in the hole just below the rear bandswitch wafer SW3D, with the following sequence, starting from the topside: 3/8" 6-32 screw, #6 internal tooth lockwasher, #6 solder terminal, 7/16" OD fiber shoulder washer (shoulder in hole), chassis, shoulder washer (shoulder in hole), #6 solder terminal, #6 internal tooth lockwasher, 6-32 hex nut.
4. () Mount a #6 solder terminal on the extension of the rear mounting screw of C8 with a 6-32 nut. Do not secure tightly at this time.
5. () Cut a 6 1/2" #16 tinned copper lead and pass one end through the topside insulated solder terminal, inserting it from the rear. Pass the lead on through the large 5/8" hole (in line with XV5) through the hole near the phenolic on pin 1 of XV5 (NS) to the hole near the phenolic on pin 6 of XV5 (NS). Pass the free end of the lead (at topside) through the hole of the solder terminal at the rear of C8 (S) and up through the hole of the rotor terminal of C8 (S). Cut off excess, train lead to the middle of the hole near XV5 and space it about 1/8" from the chassis.
6. () Cut a 3 1/2" length of #16 tinned copper lead. Place one end of the lead through the hole in the chassis just below the right stator terminal of C8B (the front stator viewed from the rear). Connect the other end to the right stator terminal of C8B (S).
7. () Mount and connect L33, the high voltage choke (marked P2428). Cut both leads to 11 1/2", strip 3/8" and tin ends. Place L33 in position, passing the leads through hole near the rear edge of chassis. Secure at all but the inner rear foot with the following hardware sequence starting from the top: 3/8" 8-32 round head screw, #8 internal tooth lockwasher, L33 foot, chassis, #8 internal tooth lockwasher, 8-32 hex nut. Train the leads along the harness to TS24. Connect one lead to terminal 1 of TS24 (S). Connect the other lead to terminal 2 of TS24 (S).
8. () Install the mic and key jack shield, SH5, in the position shown in Figure 12. Secure with four #4 x 1/4" binding head self tapping screws after the mike, key and HV choke leads have been trained in the slot and notch.
9. () Mount C9, the 360 mmf. variable capacitor, in position shown in Figure 12. Secure the capacitor in place at each end with the following hardware sequence, starting from the topside: 1/2" 6-32 round head screw, #6 internal tooth lockwasher, L33 for (only at rear), chassis, 5/16" aluminum spacer, C9 foot.
10. () Mount L11B as follows: See L6A for proper hardware sequence to attach mounting lugs. Connect and solder a 3 1/2" #16 tinned lead to the lower terminal. Train the lead downward about 30° at the terminal. Make a bend downward another 60° at a distance of 1 1/3" from the terminal. Move the coil into position, pass the bent lead through the middle of the large hole near the left front corner of C84 (viewed from the rear) and secure each of the coil lugs at the bottomside of the chassis with a #6 internal tooth lockwasher and a 6-32 hex nut. The #16 lead will be connected later.
11. () Mount SH1, the final shield in the following steps, referring to Figure 11 for orientation:
- a. () Attach a 3/8" x 7/8" aluminum L bracket, B12, to the rear of SH1 at the hole near the middle of the shield. Orient the bend of the bracket upward and secure it using hardware sequence C.

- N. 11. b. () Attach three 6-32 spade lugs to the bottom of SH1 using hardware sequence C.
- c. () Place a large fiber shoulder washer over the threaded bushing of C8 (shoulder away from C8). Place SH1 into position in front of the shoulder washer. Adjust the spade lugs until they drop into the chassis holes and secure each with a #6 internal tooth lockwasher and a 6-32 hex nut. Place the solder terminal attached to the disc ceramic capacitor, C36, between the lockwasher and nut on the spade lug near SW3A.
12. () Make #16 tinned wire top connections to L11A, the main final inductor by cutting the leads to the indicated lengths, forming a 1/16" ID open hook on one end of each lead, hooking the lead over the indicated offset between winding sections on L11A and soldering the hook in place quickly with a clean hot iron. Make connections as listed training the top leads directly away from the coil:
- a. () 5" to the middle of the offset between the five turn and the three turn sections.
- b. () 4 1/4" to the middle of the offset between the three turn and the two turn sections.
- c. () 3 3/4" to the middle of the offset between the inner two turn section and the single turn section.
- d. () 3 3/4" to the middle of the offset between the single turn section and the last two turn section.
- e. () 3 3/4" to the end of the two turn section.
13. () Mount the main final coil in position as shown in Figure 8B. Pass the five tap leads through the rear four 7/16" holes. Starting from the front of the coil the first 4 taps go into the four holes. The fifth tap goes into the second hole from the front. CAUTION - Dress the wires so they pass through the center of the holes in the chassis.
- Secure the front of the polystyrene support bar with the following sequence: 3/8" 6-32 round head screw, poly support bar, bracket BKT12, #6 internal tooth lockwasher, 6-32 nut. Secure the rear of L11A to the rear support stud, D35 with a #6 internal tooth lockwasher and a 6-32 hex nut.
14. () Make the following L11A connections:
- a. () Connect L11C, the six meter final coil from the rear of L11A (S) to the right rear stator terminal of C8A (NS).
- b. () Offset the front lead 1/8" away from the coil at a distance of 1/4" from the poly support bar. Bring the bend to the top terminal of L11B, the 160 meter auxiliary coil (S).
- c. () Bend and train the front tap lead 1/8" from the chassis bottom surface under SW3 to terminal 12 of SW3D rear (S). Do not attempt to hook leads around terminals.
- d. () Bend and train the second tap lead from the front to terminal 1 of SW3D rear (S).
- e. () Bend and train the lead from the rear of the coil to terminal 3 of SW3C rear (S).
- f. () Bend and train the third tap lead to terminal 2 of SW3D rear (S).
- g. () Bend and train the fourth tap lead to terminal 3 of SW3D rear (S).
15. () Make the following jumper connections at SW3, making right angle bends on the jumper near each terminal.

- N. 15. a. () Connect a 1 3/4" #16 jumper from terminal 5 of SW3D front (S). To terminal 3 of SW3D (S).
- b. () Connect a 1 3/4" #16 jumper from terminal 11 of SW3D rear (NS) to terminal 9 of SW3D front (NS).
- c. () Connect a 2" #16 jumper from terminal 4 of SW3C rear (S) to terminal 9 of SW3D front (S).
- d. () Cut a 7 1/4" #16 lead, form a hook on one end. Crimp the hook on the front lead of L11A (S) 1/4" from the poly support bar. Bend and train the lead through the remaining 7/16" dia. hole in the chassis, bend the free end of the lead to run 1/8" from chassis to terminal 11 of SW3D rear (S).
- e. () Connect the lead from the stator terminal of C8B to terminal 4 of SW3D front (S).
16. () Make up C38 by cutting the leads of C38A and C38B, the 150 mmf. silver mica capacitors to 1/4" and 1/2". Hook the 1/4" leads together (S). Connect one end of C38A to the insulated solder lug below SW3D (S). Connect the other end of C38B to terminal 6 of SW3D rear (S).
17. a. () Mount SW6, the auxiliary coupling switch, to shield SH7 as follows after orienting the shield so the mounting feet point toward SW6: switch, 25/64" x 5/8" x 1/16" flat washer, 3/8" lockwasher, shield, nut. Do not tighten nut at this time.
- b. () Place a 3/8" threaded panel bushing on the shaft with the hex end toward the shield.
- c. () Place a 3/8" internal tooth lockwasher on the bushing.
- d. () Insert the shaft and panel bushing through the front chassis hole. (Refer to Figure 12)
- e. () Secure SH7 to the chassis running one 6-32 x 1/4" BH screw through the shield, chassis and into C8 mounting foot. Use sequence 3 at the other mounting hole. Tighten securely.
- f. () Secure the threaded bushing into the chassis front with a 3/8-32 nut.
- g. () Position SW6 as shown in Figure 5D tighten.
18. () Connect the #16 lead coming from L11B to terminal 12 of SW6 (S) keeping the lead against terminal 11 (NS).
19. () Connect a 2 5/8" #16 lead to the center terminal of J3 (S). Connect the other end to terminal 11 of SW6 (S). Make sure the lead in step 18 is soldered at terminal 11 also.
20. () Connect a 1 1/4" #16 jumper from the rotor terminal of C9 (S) to the solder lug on J3 (S) to the rear of C9.
21. () Connect a 5/8" #16 jumper from the left stator terminal of C9 (S) to the output lead near J3 (S). Wrap the jumper around the lead.
22. () Connect a 5 1/4" #16 jumper from terminal 10 of SW3D rear (S) to output lead next to lead in step 21 (S).

- N. 23. () Connect the fixed coupling capacitors to SW6 in the following steps:
- a. () Cut one lead of each of C40A and C40B, 300 mmf. mica capacitors to 1/4" and the other lead to 5/8". Connect the 1/4" leads together (S). Connect one end of C40A from terminal 6 of SW6 (S) to solder terminal nearest top of chassis on J3 (NS).
 - b. () Cut and connect C41A and C41B, 500 mmf. mica capacitors as in step a. Connect from terminal 5 of SW6 (S) to solder terminal nearest top of chassis (S).
 - c. () Connect C42, 300 mmf. mica capacitor, from terminal 4 of SW6 (S) to solder terminal nearest lip of chassis on J3 (NS).
 - d. () Connect C43, 300 mmf. mica capacitor, from terminal 3 of SW6 (S) to solder terminal nearest lip of chassis on J3 (NS).
 - e. () Connect C44, 300 mmf. mica capacitor, from terminal 2 of SW6 (S) to solder terminal nearest lip of chassis on J3 (NS).
 - f. () Connect C45, 300 mmf. mica capacitor, from terminal 1 of SW6 (S) to solder terminal nearest chassis lip of J3 (S).
24. a. () Connect a 3" #16 tinned lead from solder terminal near pin 1 (S) of XV5 to pin 1 of XV5 (NS) to pin 4 of XV5 (NS).
- b. () Connect a 3/4" length of #16 tinned lead from pin 4 of XV5 (NS) to solder lug on TS17 (S).
25. () Connect a #16 tinned lead from pin 8 of XV5 (S) to pin 7 of XV5 (S) to terminal 2 of TS30 (S).
26. () Connect C49, .005 mfd. ceramic disc capacitor from pin 2 of XV5 (S) to the solder terminal at the rear of XV5 (S).
27. () Connect a 1 1/4" blue lead from terminal 1 of R15 (NS) to pin 3 of XV5 (NS).
28. () Connect 9A, the brown harness lead, to terminal 1 of R15 (S).
29. () Connect C46, .002 mfd. 1500 V ceramic disc capacitor from pin 3 of XV5 (S) to pin 1 of XV5 (S).
30. () Connect L8, grid parasitic suppressor, from pin 5 of XV5 (S) to terminal 3 of TS30 (NS).
31. () Connect R37, 22,000 ohm 1 watt resistor, from terminal 2 of TS17 (NS) to terminal 3 of TS17 (NS).
32. () Connect R14, 20 ohm 1/2 watt resistor, to terminal 3 of TS17 (S) and the solder terminal at the mounting foot of TS17 near XV5 (S).
33. a. () Mount TS35 (3 terminal strip with the center terminal part of the mounting foot) with one 1/4" #4 binding head sheet metal screw and one #4 shakeproof washer using the chassis hole normally used to hold the right rear mounting foot of SH2 to the chassis (see Fig. 12). Orient the terminal strip so the mounting foot is nearest the front of the chassis and the terminal strip is parallel to the rear of the chassis. This is a temporary mounting of TS35 until SH2 is mounted on the chassis using the same hole and hardware per step S14i.
- b. () Connect L7, 4 pi RF choke, from terminal 2 of TS17 (NS) to terminal 3 of TS35(NS).
- c. () Cut the leads of R57, 15,000 ohm, 1 watt resistor to 1" length. Connect one end to terminal 2 of TS17 (S) and the other end to terminal 3 of TS35 (NS).

- d. () Cut the leads of L35 and L38, 20 uh RF chokes with a red coating, to 1/2" lengths. Connect one end of L35 to terminal 3 of TS30 (NS) and the other end to terminal 1 of TS35 (NS). Connect one end of L36 to terminal 1 of TS35 (S) and the other end to terminal 3 of TS35 (NS).
- e. () Cut the leads of R16, 3900 ohm 1 watt resistor, to 3/4" lengths. Connect one end of R16 to terminal 3 of TS30 (S) and connect the other end to terminal 3 of TS35 (S).
- 34. () Connect C32, 50 mmf. mica capacitor, from terminal 1 of TS30 (NS) to terminal 2 of L6B(S). The body of the capacitor must pass the slot in the buffer shield, SH2.
- 35. () On the topside of the chassis connect C37, .002 mfd. 1500 volt mica capacitor for the stator terminal of C8A (S) to terminal 2 of L10, the RF plate choke.
- 36. () Connect C47, .002 mfd. 1500 volt ceramic disc capacitor, from terminal 1 of L10 (NS) and terminal 1 of TS31 (NS).
- 37. () Connect C48, .002 mfd. 1500 volt ceramic disc capacitor, from terminal 1 of TS31 (S) to terminal 2 of TS31 (NS).
- 38. () Connect L13, 4.7 uh RF choke, from terminal 1 of L10 (S) to terminal 2 of TS31 (S).
- 39. () Connect L9, the plate parasitic suppressor, from terminal 2 of L10 (S) to the plate cap of the 6146 (S).

O. POWER TRANSFORMER MOUNTING AND CONNECTION. Refer to Figure 11 for location and Figure 1 for terminal identification.

- 1. () Cut, strip 3/8" and tin the leads of T1, the power transformer (marked SNC 2793).
 - a. () Black - 2 1/2"
 - b. () Black - 2 3/4"
 - c. () Green - 3"
 - d. () Green - 3 1/4"
 - e. () Yellow (grouped with green and black) - 7"
 - f. () Red-yellow - 2"
 - g. () Yellow - 3 1/2"
 - h. () Red - 3"
 - i. () Red - 2 1/2"
 - j. () Blue - 5 1/4"
 - k. () Blue - 6 1/4"
 - l. () Brown - 15"
 - m. () Brown - 15"
- 2. () Put the transformer in position on the chassis pushing the black, yellow, and green leads through the rear hole and the remaining leads through the front hole.
- 3. () Secure T1 at each foot with the following hardware sequence, starting from the top of the chassis: 3/8" 8-32 round head screw, #8 internal tooth lockwasher, T1 foot, chassis, #8 internal tooth lockwasher, 8-32 hex nut.

4. () Connect the black lead (2 1/2") to terminal 4 of TS23 (S).
5. () Connect the other black lead to terminal 3 of TS23 (S).
6. () Connect the green lead (3 1/4") to solder terminal at the foot of TS23 (S).
7. () Connect the other green lead to terminal 6 of TS17 (NS).
8. () Connect the rear yellow lead, train along the chassis, to pin 8 of XV11 (S).
9. () Connect the front yellow lead, train along the harness to pin 2 of XV11 (S).
10. () Connect the red-yellow lead to the solder terminal at the mounting foot of TS23 (S).
11. () Connect the red lead (2 1/2") to pin 6 of XV11 (S).
12. () Connect the other red lead to pin 4 of XV11 (S).
13. () Connect the blue lead (6 1/4") to pin 5 of XV12 (S).
14. () Connect the other blue lead to pin 3 of XV12 (S).
15. () Train both brown leads along the side of the chassis toward the front and route up through the ventilating hole between XV12 and the square cutout for SW4. These two leads will be connected to the keyer plate later.

P. AUXILIARY POWER SOCKET AND LINE FILTER ASSEMBLY AND WIRING. Refer to Figures 1a and 9a.

1. () Prepare and mount J6 in the following steps:
 - a. () Cut off all of the pin terminals of the 9 pin socket just below the upper hole (socket viewed from the bottom).
 - b. () Cut eight pieces of #16 tinned wire 15/16" long. Form a 1/8" long hook on the end of each.
 - c. () Hook, crimp and solder the short pieces of wire to the pins, except pin 9, extending the straight ends directly away from the terminals.
 - d. () Form a 1/8" hook on a 2" #16 tinned lead. Hook, crimp and solder the lead to pin 9 of J6 with the lead extending directly away from the terminal.
 - e. () Mount J6 and the shield SH4, (refer to Figure 1), passing the J6 leads through the shield holes. Secure J6 and SH4 with the following hardware sequence. Starting from the outside: 3/8-6-32 round head screw, #6 internal tooth lock-washer, J6 mounting foot, chassis, SH4 mounting foot, #6 internal tooth lock-washer, two #6 solder terminals, 6-32 hex nut. Pins 1 and 9 should be toward the chassis lip.
 - f. () Bend the long lead (from pin 9 of J6) to the solder terminal pointing toward the chassis lip on the screw toward the middle of the chassis (S).
 - g. () Cut and push 7/16" lengths of .051 I.D. varnished tubing over the remaining 8 leads of J6 insulating them from SH4.
2. () Connect the bypass condensers to the auxiliary socket and line filter in the following order, making the connections to J6 extensions by looping the condenser leads around the extension near the varnished tubing. Maintain 1/16" of clearance between the condenser bodies and the SH4 shield.

3. () Connect C83, .002 mfd. 1500 volt ceramic disc capacitor, from pin 5 of J6 (NS) to nearest solder terminal on SH4 (NS).
4. () Connect C79, .005 mfd. ceramic disc capacitor, from pin 4 of J6 (NS) to nearest solder terminal on SH4 (S).
5. () Connect C66, .002 mfd. 1500 volt ceramic disc capacitor, from pin 3 of J6 (NS) to nearest solder terminal (NS).
6. () Connect C68, .002 mfd. 1500 volt ceramic disc capacitor from pin 2 of J6 (NS) to nearest solder terminal (NS).
7. () Connect C67, .002mfd. 1500 volt ceramic disc capacitor, from pin 1 of J6 (NS) to nearest solder terminal (S).
8. () Connect C84, .002 mfd. 1500 volt ceramic disc capacitor, from pin 6 of J6 (NS) to nearest solder terminal (NS).
9. () Connect C75, .005 mfd. ceramic disc capacitor, from pin 7 of J6 (NS) to nearest solder terminal (NS).
10. () Connect C74, .005 mfd. ceramic disc capacitor, from pin 8 of J6 (NS) to nearest solder terminal (S).
11. () Connect C62B, .005 mfd. ceramic disc capacitor, from terminal 1 of J4 (NS) to solder terminal to the left of J4 (S).
12. () Connect C63A, .005 mfd. ceramic disc capacitor, from terminal 2 of J4 (NS) to solder terminal to the left of J4 (NS).
13. () Connect C61B, .005 mfd. ceramic disc capacitor, from terminal 5 of TS28 (NS) to the solder terminal to the left of J4 (S).
14. () Connect C62A, .005 mfd. ceramic disc capacitor, from terminal 1 of TS29 (NS) to solder terminal at foot of TS29 (S).
15. () Connect C63B, .005 mfd. ceramic disc capacitor, from terminal 3 of TS29 (NS) to solder terminal near chassis lip on foot of TS29 (NS).
16. () Connect C61A, .005 mfd. ceramic disc capacitor, from terminal 5 of TS29 (NS) to solder terminal on the foot of TS29 (S).
17. () Connect 1" #20 tinned lead from terminal 1 of J4 (S) to terminal 1 of TS28 (NS).
18. () Connect 1" #20 tinned lead from terminal 2 of J4 (S) to terminal 3 of TS28 (NS).
19. () Connect L20, 4.7 uh RF choke, from pin 5 of J6 (S) to terminal 1 of TS17 (S).
20. () Connect L21, 4.7 uh RF choke, from pin 6 of J6 (S) to terminal 4 of TS17 (S).
21. () Connect L22, 4.7 uh RF choke, from pin 4 of J6 (S) to terminal 1 of TS25 (S).
22. () Connect L17, 4.7 uh RF choke, from pin 3 of J6 (S) to terminal 2 of TS25 (S).
23. () Connect L19, 4.7 uh RF choke, from pin 2 of J6 (S) to terminal 3 of TS25 (S).
24. () Connect L18, 4.7 uh RF choke, from pin 1 of J6 (S) to terminal 3 of TS24 (S).
25. () Cut thirteen pieces of #18 formex wire 28 1/2" long. Strip 3/8" of insulation off each end. Straighten the wires by drawing them through the fingers. Using the

P. 25. wood dowel furnished for this purpose, wind twelve close round coils each with 19 turns. Bend the ends of the coil leads at right angles to form terminals. Tin the ends with solder and make the following connections.

26. () Connect L26B from terminal 1 of TS28 (S) to terminal 1 of TS29 (NS).
27. () Connect L27A from terminal 3 of TS28 (S) to terminal 3 of TS29 (NS).
28. () Connect L25 B from terminal 5 of TS28 (NS) to terminal 5 of TS29 (NS).
29. () Connect L26 A from terminal 1 of TS29 (S) to terminal 1 of TS23 (S).
30. () Connect L27B from terminal 3 of TS29 (S) to terminal 3 of TS23 (S).
31. () Connect L25A from terminal 5 of TS29 (S) to terminal 5 of TS23 (S).
32. () Connect L24 from terminal 6 of TS17 (S) to pin 7 of J6 (S).
33. () Connect L23 from terminal 5 of TS17 (S) to pin 8 of J6 (S).

Q. HV BLEEDER, LV CHOKE AND HV FILTER CONDENSER MOUNTING AND WIRING.

1. () Mount and connect R35, the 20,000 ohm, 50 watt power resistor, as follows.
2. () Mount one of the end supporting brackets on the side of the chassis near the drive control R13. Use hardware sequence A.
3. () Connect a 1 7/8" #20 tinned lead to the solder terminal just installed (S).
4. () Adjust the tap of R35 to the center of the resistor, taking care to loosen the band screw sufficiently.
5. () Push R35 over the V end of the bracket, orienting it in position as shown in Figure 12. Push the other mounting bracket into the rear end and secure it in position near XV11. Using hardware sequence C.
6. () Connect terminal 1 of R35 (NS) to pin 1 of XV11 (S) use #20 tinned wire.
7. () Connect the tinned lead installed in step 3 to terminal 3 of R35 (S).
8. () Connect 36A, gray harness lead to the adjustable tap on R35 (S).
9. () Mount L34, the low voltage filter choke, (marked P1501) as follows.
10. () Cut the leads to 5" length. Strip 3/8" and tin each lead.
11. () Mount L34 on the chassis side with the leads toward the chassis top. The leads should be trained between XV11 and the side of the chassis to XV12. Use the following hardware sequence starting from the outside of the chassis: 6-32 x 2 1/2" screw, #6 internal tooth lockwasher, chassis, L34 mounting foot, 2 1/16" aluminum spacer, 6-32 hex nut.
12. () Connect one choke lead to pin 8 of XV12 (S).
13. () Connect the other choke lead to terminal 2 of TS15 (NS).
14. () Mount C77, the high voltage 10 mfd. 700 volt electrolytic capacitor, to the front mounting stud of the low voltage choke L34. Secure the strap near the positive end to the screw extension at the front of L34 with a #6 internal tooth lockwasher and a 6-32 hex nut.

- Q. 14. Cut the negative lead to 1 3/8" and the positive lead to 2 3/4" length. Secure a #6 solder terminal to the rear post of L34 with a #6 internal tooth lockwasher and a 6-32 hex nut.
15. () Connect and solder the negative lead of C77 to solder terminal just installed (S).
 16. () Connect and solder temporarily the positive lead to terminal 2 of TS15.
 17. () Assemble and connect line cord as follows.
 18. () Tie an overhand knot on one end of the line cord at a distance from the end so that 1 1/16" extends beyond the knot when it is tight.
 19. () Part the conductors at the middle for a distance of 1". Strip and tin 3/8" at the end of each lead. Thread the untied end through the grommet G6 near TS25 from the inside of the chassis.
 20. () Connect one lead to terminal 2 of J4 (S).
 21. () Connect other lead to terminal 5 of TS28 (S).
 22. () To prepare the line cord for attaching the power plug P1, slit the wires apart back 2". Strip off 1/2" of insulation, tin each lead. Tie the ends together in an overhand knot at the point where they were split apart.
 23. () Disassemble the line cord plug P1. Attach one line cord lead to each of the fuse clips in the plug, fastening the leads with the screws. Reassemble the plug with the knot inside the plug. Place the 5 ampere fuse and the 3 ampere Fusetron or Slow Blo in the plug.
 24. () Install extension shafts and couplings as follows:
 25. () Place a 3/8" bushing in the front chassis hole in line with C9. Use hardware sequence G.
 26. () Install D29, 7 1/4" shaft with a rigid metal coupling and four 3/16" 8-32 setscrews.
 27. () Secure a large fiber shoulder to the shaft bushing of C8 with a 3/8-32 nut. Place the shoulder toward the final shield.
 28. () Install D30, 6 7/16" shaft to C8 with a rigid fiber coupling and four 1/8" 8-32 setscrews.
 29. () Install D31, 5 5/16" shaft to C7 with a rigid metal coupling and 1/8" 8-32 setscrews.
 30. () Make the following pilot light leads with green wire, training leads as indicated in Figure 11.
 31. () 11" length from terminal 3 of SW4B (S).
 32. () 11" length from terminal 4 of SW4B (S) to X14 bracket type socket assembly (S).

R. KEYER CONTROL UNIT ASSEMBLY

1. () Using the diagram, Figures 13a and b, mount the following components making sure that the tube sockets and variable resistor are oriented as shown, and also mounted on the correct side of the Keyer Chassis plate, CH13.
2. () Mount XV13, the 7 pin miniature socket using hardware sequence D on the foot near pin 4 and 5. Use hardware sequence E on the other foot.
3. () Mount XV14, the 9 pin miniature socket using hardware sequence E.

- R. 4. () Mount TS37, 6 terminal strip, as shown using hardware sequence A.
5. () Mount R39, 100,000 ohm potentiometer, using hardware sequence G.
6. () Using one of the 1/4" 6-32 binding head screws, mount the 1 3/8" x 1/4" tapped aluminum post in the hole provided near the 9 pin socket XV14.
7. () Grasp the mounting strap of C90A and B, dual 15 mfd. 150 V. electrolytic capacitor, firmly in a pair of long nose pliers. Carefully twist the mounting strap until it is 90° to its original position in order to be able to mount the capacitor vertically on the post just installed.
8. () Cut the green and red leads of C90 to 2" length. Strip 5/16" and tin the ends.
9. () Cut the black and blue leads to 3" length. Strip 5/16" and tin the leads.
10. () Mount C90 as shown in Figure 13A with the black and blue leads near the plate. Use a 1/4" 6-32 binding head screw, #6 internal tooth lockwasher, and a #6 solder terminal for mounting.
11. () Connect the red and green leads to solder terminal just installed (S).
12. () Connect the black and blue leads of C90 to terminal 3 of TS37 (NS).
13. () Make the following connections using #20 tinned wire.
14. () Connect pin 4 of XV14 (NS) to center shield of XV14 (NS) to pin 5 of XV14 (S) to ground terminal on XV14 (NS).
15. () Connect pin 3 of XV13 (S) to center shield of XV13 (S) to ground terminal near pin 3 (S).
16. () Connect terminal 1 of R39 (S), the 100,000 ohm potentiometer, and the ground terminal near pin 1 of XV14 (S).
17. () Connect a 1 1/2" length of green lead from pin 4 of XV13 (S) and pin 9 of XV14 (NS).
18. () Connect a 1" length of black wire from pin 2 of XV13 (S) to pin 7 of XV13 (NS).
19. () Connect a 1 1/2" length of black wire from pin 7 of XV13 (S) and terminal 6 of TS37 (NS).
20. () Connect a 3 1/4" length of white wire from terminal 3 of TS37 (NS) to terminal 3 of R39 (S).
21. () Connect R38, 22,000 ohm 1/2 watt resistor, from pin 1 of XV14 (NS) to ground terminal near pin 3 (S).
22. () Connect a 1" length of blue wire from pin 3 of XV14 (S) to pin 8 of XV14 (NS).
23. () Connect R40, 1 megohm 1/2 watt resistor, from pin 2 of XV14 (S) to terminal 2 of R39 (S).
24. () Connect R41, 18,000 ohm 1/2 watt resistor, from terminal 3 of TS37 (NS) to pin 8 of XV14 (S).
25. () Connect R42, 100,000 ohm 1/2 watt resistor, from terminal 3 of TS37 (NS) to pin 7 of XV14 (NS).
26. () Connect R43, 47,000 ohm 1/2 watt resistor, from terminal 1 of TS37 (NS) to pin 7 of XV14 (NS).
27. () Connect C89, .047 mfd. 200 volt capacitor, from terminal 1 of TS 37 (NS) and pin 4 of XV14 (S).

- R. 28. () Connect R46, 100,000 ohm 1/2 watt resistor, from terminal 1 of TS37 (NS) to terminal 2 of TS37 (NS).
29. () Connect R44, 330,000 ohm 1/2 watt resistor, from terminal 2 of TS37 (NS) and the ground terminal on TS37 (S).
30. () Connect R54, 6800 ohm 2 watt resistor, from terminal 3 of TS37 (NS) to terminal 6 of TS37 (S).
31. () Connect R52, 4700 ohm 1/2 watt resistor, from terminal 3 of TS37 (S) to terminal 5 of TS37 (NS).
32. () Connect R53, 4700 ohm 1/2 watt resistor, from terminal 5 of TS37 (NS) to solder terminal near terminal 6 of TS37 (S).
33. () Connect a 20 1/2" black lead to terminal 5 of TS37 (S). Route against chassis and over to terminal 1 of TS37. Bend at a right angle to TS37 away from TS37 and XV14.
34. () Connect a 8 1/2" green lead to pin 9 of XV14 (S). Route along chassis as step 33.
35. () Connect a 14" orange lead from pin 1 of XV14 (S). Route the same as lead in step 34.
36. () Connect a 11 1/4" yellow lead from terminal 1 of TS37 (S). Route the same as lead in step 35.
37. () Connect a 8" gray lead from pin 7 of XV14 (S). Route the same as lead in step 36.
38. () Connect a 8 1/2" red lead from pin 6 of XV14 (S). Route the same as lead in step 37.
39. () Connect a 12 1/4" white lead from terminal 2 of TS37 (S).
40. () Train all leads from keyer together in a cable, and away from the chassis at a right angle to terminal strip TS37. A few pieces of narrow tape may be placed around the wires near TS37 and also at a point not over 3" from the chassis to hold the cable together.
41. () The keyer plate assembly will be mounted on top of the three 2 15/16" spacers directly above the operate switch wafers and V3, the 6CL6 oscillator stage.
42. () Train all leads from the keyer assembly through the ventilating hole between SW4 and XV12. The brown transformer leads have already been trained up toward the keyer through this hole.
43. () Train the two transformer leads along the balance of the keyer leads and over to the 7 pin socket XV13. The leads may be laced or taped for neatness.
44. () Connect one of the brown leads to pin 5 of XV13 (S).
45. () Connect the other brown lead to pin 1 of XV13 (S).
46. () Carefully place the keyer chassis in place on the three spacers, making sure not to disturb the terminals on SW4A and B. After the keyer is in place temporarily secure by placing 1/4" 6-32 binding head screws, #6 internal tooth lockwashers, through the mounting holes provided and into the spacers.
47. () Invert the transmitter and train the green, red and gray leads over to TS15 and the white, orange and black leads along the harness near the front edge of the chassis.
48. () Connect the orange lead to terminal 8 of TS34 (S).

- R. 49. () Connect the white lead to terminal 7 of TS34 (S).
 50. () Connect the green lead to pin 7 of XV12 (S).
 51. () Connect the red lead to terminal 2 of TS15 (S).
 52. () Connect the gray lead to terminal 3 of TS15 (S).
 53. () Connect the yellow lead to terminal 2 of TS39 (S).
 54. () Connect the black lead to terminal 4 of TS20 (S).

S. VFO PRELIMINARY TESTS

1. () Temporarily place 1 1/8" knobs on SW5, SW4, SW2, SW3, R13 and C7 shafts. (Use 3/16" 8-32 setscrews).
 2. () Temporarily connect the meter M1 to the black and red meter leads with 1 to 2 foot lead extensions. Connect the red lead to the + terminal of M1. Be careful with the meter while testing. Lay the meter in its box to keep it from being damaged during these tests.
 3. () Spread the tube clips of the miniature sockets with a heavy needle or a scribe to prevent bending or breaking tube pins and place tubes (only those listed) in the sockets as follows:

OA2 in the front socket of the VFO.
 6AU6 in the rear socket of the VFO.
 6AX5 in the V12 position shown in Figure 11.
 6CL6's in the V3 and V4 positions.
 6146 in the V5 position. Place the plate cap on the 6146.

12AU7 in the V14 position.
 6AL5 in the V13 position.
 5763 in the V15 position.

4. () Make the following switch and condenser settings (viewed from the front of the chassis):
 "VFO Tuning" C1 - counter-clockwise
 all trimmers in the VFO - mid-position
 "Operate SW" SW4 - counter-clockwise
 "Band SW" SW3 - first step away from the counter-clockwise position.
 "Meter SW" SW5 - first step away from the counter-clockwise position.
 "Xtal-VFO-SW" SW2 - first step away from the clockwise position.
 "Keyer Control" R39 - counter-clockwise.
5. () Make the #20 tinned wire jumper connections listed, and plug in the 9 prong octal style male plug, P3, as outlined below:
- a. () 2 1/2" length between pins 3 and 5.
 b. () 2 3/4" length between pins 2 and 6.
 c. () 2 1/4" length between pins 7 and 8.
 d. () Solder the ends of the pins with a hot iron and trim any excess beyond the solder connection.
 e. () Push the cover shell on the back of the receptacle.
 f. () Plug P3 into J6.

- S. 6. () Plug P1 into a 115 volt AC outlet.
7. () Turn SW4, the operate switch, one step clockwise and observe the filaments of the tubes. All should light.
8. () Note the meter reading. It should be between 24 ma and 32 ma on 40 ma scale. This may be lower on the 15 and 20 meter bands.
9. () Short circuit the close wound coil on L1 with a screwdriver. A marked rise in meter current should be noted if the VFO is operating. If this rise is not noticed, check leads and terminals for clearance and the circuits for correctness.
10. () Listen for the VFO signal on a receiver. It should be found within 100 kc of 1725 kc. When C1 is turned clockwise, the signal should be found within 100 kc of 1980 kc.
11. () Turn the meter switch one step clockwise and note that the buffer current rises when the drive control R13 is advanced about 1/3 of the distance from the counter-clockwise position. Turn the meter switch another step clockwise and note a rise in grid current when the buffer tuning control C7 is tuned to the VFO frequency. Keep the grid current below 3 ma on the 10 ma scale. If no grid current is noted, check the oscillator amplifier circuit of X3 and the buffer circuit of X4.
12. () Turn the meter switch SW5 to the first step from the counter-clockwise position, the bandswitch to the third position (40 meter) from the counter-clockwise position.
13. () Repeat tests of steps 9, 10 and 11. The VFO signal should now be found within 200 kc of 6800 kc when C1 is counter-clockwise and within 200 kc of 7250 kc when C1 is clockwise. In this case, L1A should be shorted.
14. () Disconnect the power plug. Disconnect the meter, remove all tubes except those in the VFO, remove the knobs, and attach the VFO shields. Refer to Figure 11.
- a. () Place a small drop of oil on the C1 shaft near each end bearing.
- b. () Attach the top shield, CH5, in the following steps:
- () Pre-tap the eight holes in the flanges of CH5 with a well-lubricated 1/4" #4 binding head sheet metal screw.
 - () Force a 7/16" OD "C" washer over each of the inner slots of the five insulated trimmer shafts, D32 (refer to Figure 10A).
 - () Place the coupling springs and trimmer shafts over the trimmer condensers C2, C3, C4, C5 and C6 of the VFO as shown in Figure 10A while putting the top shield, CH5, in place. The springs may be distorted slightly with a pliers so that the spring is retained by the shaft slot.
 - () Secure CH5 in place with a 1/4" 6-32 binding head screw at each of the rear posts and at the right (viewed from the front) front post. Secure at the left front post with the following hardware sequence: 1/4" 6-32 binding type screwhead, #6 solder terminal (pointing toward the front), #6 internal tooth lockwasher, CH5, VFO post.
 - () Check the centering of CH5 and the assembly of each of the trimmer shafts. Remove the springs, open them slightly and reinsert if there is insufficient force against the shafts to hold the springs in place securely. Set each trimmer condenser at mid-position.

- S. 14.
- b. 6. () Force a 7/16" OD "C" washer over each of the outer slots of the five insulated trimmer shafts on the outside of CH5.
 - c. () Prepare and attach the VFO shield, SH3, in the following steps:
 - 1. () Pre-tap the six holes on the flanged side of CH7 with a well lubricated 1/4" #4 binding head sheet metal screw.
 - 2. () Secure six #6 spade lugs to the bottom end of SH5, the end nearer the 1/2" hole on one side, using the following sequence starting from the inside: 1/4" 6-32 binding type screwhead, SH3, spade lug, #6 internal tooth lockwashers, 6-32 nut.
 - 3. () Slide SH3 over the VFO in such a way that the spade lugs engage the chassis holes. The 5/8" hole will be toward the front of the chassis. It may be necessary to spread the flanged end of SH3 somewhat while it is sliding over the VFO to allow the spade lug screwheads to pass over CH5 and the phenolic plate.
 - 4. () Secure each of the two back and two side spade lugs with a #6 internal tooth lockwasher and a 6-32 nut.
 - 5. () Prepare C78, the 30 mfd 450 volt electrolytic capacitor, by cutting the positive lead to 1 1/2" and the negative lead to 1 1/4" length. Solder a #6 solder terminal to the negative lead.
 - 6. () Secure C78 at the front spade lugs of SH3 by mounting the C78 strap between the lockwasher and chassis on the left front (viewed from the bottom front) spade lug and the negative lead solder terminal between the shakeproof and nut of the right spade lug as shown in Figure 12 while each lug is secure with a #6 internal tooth lockwasher and a 6-32 nut.
 - 7. () Slip a 1" piece of varnished tubing over the positive lead of C78 and connect that lead to terminal 1 of TS19 (S).
 - 8. () Remove the positive lead of C77, the 10 mfd, 700 volt electrolytic capacitor, from terminal 2 of TS15 and connect it to the ungrounded terminal of the bleeder resistor R35 (S).
 - d. () Secure SH3 to CH5 with six 1/4" #4 binding head sheet metal screws and #4 shakeproofs. Attach TS33 (as shown in Figure 11) between the lockwasher and SH3 on the front screw of the right side.
 - e. () Secure the short 1/4" shaft end of the planetary drive, D3, to the flexible coupling on C1, the VFO tuning capacitor. Insert the screwdriver blade through the hole in the chassis just below C1 and tighten both setscrews when D3 has been positioned so that the hex shoulder extends about 1/32" beyond the chassis front surface when a straight edge is laid on the surface extended to D3. Temporarily attach the dial pointer D8, to the planetary sleeve with the 1/8" 4-40 screw. Rotate C1 to the counter-clockwise position and note the position of the end of the pointer. Now move the pointer until the rotor plates of C1 (viewed from the open side of the VFO) are as nearly exactly meshed as can be determined. Write down the length of the arc between the meshed position and the counter-clockwise position of C1. This arc length will be used to set up the dial later. It may vary from zero to 3/16". Remove the dial pointer D3. Take care in the following steps to keep from applying undue forces on the planetary drive thus impairing the coupling.
 - f. () Attach spade lugs to the bottom of the side plate, CH9. The bottom has holes with 2 1/2" spacing while the holes at the top are spaced 2". Use the following sequence

- S. 14.
- f. at each hole: 1/4" 6-32 binding type screwhead, #6 spade lug, CH6, #6 internal tooth lockwasher, 6-32 nut.
 - g. () Place CH6 in position (spade lugs outside) and secure the spade lugs at the bottom of the chassis with #6 internal tooth lockwasher and 6-32 nuts. Remove the outer mounting screw of J5 and move J5 out of position to reach the front spade lug. Resecure J5 after the CH6 spade lugs are tightened.
 - h. () Secure CH6 to SH3 with eight 1/4" #4 binding head sheet metal screws and #4 lockwasher. Attach TS32 (as shown in Figure 11) between the lockwasher and CH6 on the top screw.
 - i. () Secure the buffer shield, SH2, in place as shown in Figure 12 with four 1/4" #4 binding head sheet metal screws and #4 shakeproof washers. Temporarily remove the screw mounting TS35 and use this same screw to remount TS35 and the right rear mounting foot of SH2. Train the wires and components to clear the slots in SH2. Lubricate the screws before starting them into the chassis.

T. FRONT PANEL PREPARATION AND MOUNTING. Refer to Figure 6B, 6C in the Operating Manual and Figures 10E and 11 in the Assembly Details. Use a rug or soft pad to protect the panel in this part.

- 1. () Attach the meter and the meter shield bracket to the front panel with the hardware in the meter box. Lay the panel face down with the meter properly positioned beneath it. Place the meter shield bracket over the meter mounting studs and secure with the hardware furnished with meter. Turn a 1/4" -28 nut to 1/2" from back side of meter on each stud.
- 2. () Prepare and mount the meter shield cover, SH6, as follows:
 - a. () Attach a 3 terminal strip, TS27, to SH6 with hardware at each foot in the following sequence, starting from the inside. Place a 1/4" 6-32 binding head screw in the two holes. Place a #6 lockwasher on each screw, plate the terminal strip on the screws, place a #6 solder lug on each screw. Place a 6-32 hex nut on each screw and tighten securely.
 - b. () Place a 1/4" -28 nut on each of the meter studs and turn them down to a point 1/2" above the meter case. Place SH6 over the rear of the meter with the meter studs protruding through the holes in the shield. Secure SH6 using following hardware sequence on each stud starting at the meter shield: 5/8" fiber shoulder washer (small diameter toward shield), 1/4" flatwasher, 1/4" -28 nut. Tighten nut securely. Place 1/4" hole diameter solder terminal on each meter stud (pointing outward), a 1/4" -28 nut and tighten securely.
 - c. () Connect C64, .002 mfd ceramic disc capacitor, 3/4" leads, between the terminal 2 of M1 and the near solder terminal of TS27 (S). Connect C65, .002 mfd ceramic disc capacitor, between terminal 1 of M1 and near solder terminal at TS27 (S). Refer to Fig. 9B.
 - d. () Connect one of the 19 turn VHF chokes, L28, previously made up, between terminal 2 of M1 (S) and terminal 3 of TS27 (NS).
 - e. () Connect another 19 turn VHF choke, L29, between terminal 1 of M1 (S) and terminal 1 of TS27 (NS).
- 3. a. () Attach two 9/16" 4-40 cadmium plated screws to the panel in the two holes directly above the exciter and final tuning capacitor shaft holes. Secure each with the following sequence, starting from the rear of the panel: Screwhead, panel, #4 internal tooth lockwasher, 4-40 nut secured tightly.

- T. 3. b. () Attach a #6 solder terminal to the lip corner (near the upper middle of the top flange) of the panel with a 1/4" 4-40 screw, a #4 internal tooth lockwasher, and a 4-40 nut. Point the solder terminal away from the middle tapped extruded hole.
4. () Remove the temporary mounting legs from the chassis. Save the #10 screws for a later operation.
 5. () Place the 3/4" internal shakeproof washer over the planetary bushing and bring the front panel to position on the chassis. Make minor adjustments of bushing position if necessary and secure the panel to the 3/8" bushings with 3/8" -32 nuts. Place 1" O.D. flat washer over planetary bushing. Secure the planetary to the panel with the 3/4" -20 nut. If undue strain is noted on the planetary coupling as the panel nut is tightened, loosen the coupling setscrews (through the chassis hole) and reposition the planetary shaft.
 6. () Push the 3/16" diameter metaltex braid between the panel strips and the flange (as shown in Figure 6B) and between the panel flange and chassis lip. Start at the middle of the lower flange and push the braid in place with a screwdriver - taking care to train the braid fully and smoothly around the corners for good electrical seal. Cut off any excess after the braid has been brought completely around and has been trained fully in every corner.
 7. () Connect and solder the free red lead from the meter switch, SW5, to terminal 3 of TS27 (viewed from the rear in Figure 6B). Connect and solder the black lead to terminal 1 of TS27.
 8. () Place a #51 mazda lamp in each of the two sockets, XI1 and XI2.
 9. () Connect C80 and C81, each a .005 mfd. disc ceramic condenser, to XI1 and XI2 respectively as follows:
 - a. () Cut the leads of each to 5/8".
 - b. () Connect each condenser between the solder lug on the contact rivet and the socket shell. Make the shell connection by soldering the condenser lead directly to the shell just beyond the barrel rib. Scrap the plating off a small area if the plating does not accept solder.
 - c. () Move the keyer plate aside to permit access to SW4.
 10. () Place the pilot light assemblies XI1 and XI2 in the 5/8" holes on the panel. Connect the 19 turn VHF chokes L31 and L32 as follows. Refer to Figure 6B and Figure 11.
 - a. () L31 between the terminal 1 of TS33 (S) and the solder terminal on XI2 (S).
 - b. () L32 between terminal 2 of TS32 (NS) and the solder terminal of XI1 (S). Connect the 11" green lead from terminal 3 of SW4B to terminal 2 of TS32 (NS). Connect a 4" green lead from terminal 2 of TS32 (NS) to X13 bracket type socket assembly (S). Connect a 10" length of green wire from terminal 2 of TS32 (S) to terminal 1 of TS33 (S).
 11. () Prepare the dial as shown in Figure 6C in the following steps:
 - a. () Secure the dial plate, D5, to the inside of the escutcheon, D4, as shown with the two jewels, D9A and D9B, and a 9/32"-27 nut on each jewel, jammed against D5. D9A, the red jewel, will be on the right side; D9B, the green jewel, will be on the left side as viewed from the front.
 - b. () Place the rubber gasket, D6, around the edge of D4 and cut off any excess. The gasket should meet at the bottom of D4.
 - c. () Apply the rubber weatherstrip light blocks, D7, as shown in Figure 6C, making certain that there is over 3/16" of distance between the arc of the escutcheon opening.

- T. 11. c. and the light block rubber. The dial pointer will move in this area later.
- d. () Turn on another 9/32"-27 spacing nut on each of the jewels until the upper surface (viewed from the inside of the escutcheon) of the nut is just 1/32" below the level of a straight edge held across the gasket of D4.
- e. () Place a 4-40 nut on each of the 9/16" screw extensions on the front panel. Turn each nut on until the front surface of the nut is exactly 5/16" from the surface of the panel.
- f. () Place the dial pointer, D8, over the planetary sleeve. The rivet head at the top of the pointer should be outward. Leave 1/32" clearance between the 3/4" bushing on the planetary drive and the pointer hub. Secure the hub to the sleeve with the pointer on the left side-space below the horizontal position by the arc length measured and noted in step N14e, when VFO condenser, C1, is in the most counter-clockwise position.
- g. () Place the dial assembly in position on the panel and secure it in place with 4-40 nuts over the 9/16" 4-40 screws, the pilot light bracket, XI3, a 9/32"-27 nut on the left jewel, and the pilot light bracket, XI4, and a 9/32"-27 nut at the rear of the panel on the right jewel. Place a #51 lamp in XI3 and XI4 and bend the brackets to bring the lamps as near the jewel openings as possible.
12. () Connect the solder terminal at the lip near the middle of the upper flange of the front panel (S) to the solder terminal on the upper, front, left corner of the VFO with a 1 1/4" doubled piece of #20 tinned wire (2 1/2" total length) (S).
13. () Inspect all of the chassis carefully, looking for obvious mistakes, unsoldered connections, touching uninsulated leads, or omissions. Train any looped leads near the chassis to prevent pickup in the harness and tie any loose leads to the harness with lacing cord or tape.
14. () Letter "High Voltage" warnings on the upper part of the meter shield, on the chassis near the high voltage bleeder resistor, R35, the auxiliary socket shield SH4 and on the topside of the chassis near the Final RF choke, L10, and near the Operate switch, SW4. Decals or pressure sensitive marking tapes may be used for greater neatness.
15. () Place a small drop of oil on each condenser, switch, planetary, and panel bearing.
16. () Place the keyer control unit on the three aluminum spacers D36, 37, 38. Secure with three 1/4 x 6-32 binding head screws and #6 internal tooth lockwashers.

U. TRANSMITTER TEST.

1. () Attach the knobs as follows at each panel position.
- a. () Operate - 1 1/8" knob, 3/16" 8-32 setscrew and a 1/4" deformed washer making contact between the knob and bushing. The white indicator on "Off" when the operate switch is counter-clockwise.
- b. () Exciter - 1 1/8" 100-0 dial knob and a 3/16" 8-32 setscrew. The green indicator should be aligned on "0" when the buffer condenser is meshed. Set so that the skirt just clears the 4-40 nut.
- c. () Final - 1 1/8" 100-0 dial knob and 3/16" 8-32 setscrew. The green indicator should be aligned on "0" when the final condenser is meshed. Set so that skirt is clear of 4-40 nut.

- U. 1.
- d. () Meter - 1 1/8" knob, 3/16" 8-32 setscrew and a 1/4" deformed washer. Indicator on "Off" when the meter switch is counter-clockwise.
 - e. () Drive - 1 1/8" knob, 3/16" 8-32 setscrew and a 1/4" deformed washer. Indicator on "0" when the drive control is counter-clockwise.
 - f. () Crystal - VFO - 1 1/8" knob, 3/16" 8-32 setscrew and 1/4" deformed washer. Indicator on "Xtl" when the Crystal-VFO switch is counter-clockwise.
 - g. () Crystals - bend the fingers of the 1 1/2" plug button inward until the plug can be inserted into the crystal well hole while still providing good electrical contact at least five or six places around the hole. Make certain all of the contacts are free of paint to assure good electrical contact. This cover must be on when the transmitter is in the cabinet to insure good TVI rejection.
 - h. () Band - 1 5/8" knob, 3/16" 10-32 setscrew, and a 1/4" deformed washer. Indicator on "160" when the bandswitch is in the most counter-clockwise position. Set the setscrew very tightly.
 - i. () Auxiliary coupling - 1 1/8" knob, 3/16" 8-32 setscrew, and a 1/4" deformed washer. Indicator on "1" when the coupling switch is counter-clockwise.
 - j. () Coupling - 1 1/8" knob, 3/16" 8-32 setscrew, and a 1/4" deformed washer. Indicator on "0" when the coupling condenser is meshed.
 - k. () Audio - 1 1/8" knob, 3/16" 8-32 setscrew, and a 1/4" deformed washer. Indicator on "0" when the audio control is counter-clockwise.
 - l. () VFO - 2 1/8" knob and a 3/16" 10-32 setscrew. Place star spring on shaft with fingers toward knob. Push the knob on the shaft as far as it will go - clearing the dial escutcheon.
2. () Place tubes in the sockets as shown in Figure 11 as listed below:
- a. () V3 - 6CL6, Oscillator - Multiplier.
 - b. () V4 - 6CL6, Buffer.
 - c. () V12 - 6AX5GT, Low Voltage Rectifier.
 - d. () V11 - 5R4GY, High Voltage Rectifier.
 - e. () V5 - 6146, Final Amplifier.
 - f. () V9 and V10 - 7027, Modulators.
 - g. () V8 - 12AU7, Audio Driver.
 - h. () V7 - 12AX7, Speech Amplifier.
 - i. () V6 - 6AQ5, Clamper Tube.
 - j. () V13 - 12AU7, Keyer Control Tube.
 - k. () V14 - 6AL5, Bias Rectifier.
 - l. () V15 - 5763, Buffer.

- U. 3. () Place 160 or 80 meter crystal (243 type or similar holder) in the crystal socket position XT1 and a 40 meter crystal at XT2 as shown in Figure 10D. Loop a 3 1/2" x 1/2" friction, masking or plastic tape around each crystal to form a pull out tab.
4. () Set the controls in the listed positions:
- a. () Operate - Off
 - b. () Drive - 0
 - c. () Crystal - VFO - on VFO
 - d. () Band - 40
 - e. () Auxiliary Coupling - 1
 - f. () Coupling - 0
 - g. () Audio - 0
 - h. () Meter - Osc.
 - i. () VFO pointer on 7 mc.
5. () Connect a 60 watt or 100 watt lamp bulb to the output of the transmitter at J3 with short (less than 2 ft.) leads or a short piece of coaxial cable. A banana plug may serve as a connector to J3 and the ground screw can be used if a coax connection is inconvenient.
6. () Check the transmitter on 40 meters as outlined below. The other bands will be similar and will require little further discussion. Typical voltage, current and resistance values are given in the Operating Manual.
- a. () Plug P1 into an AC receptacle, 117 volts.
 - b. () Turn "Operate" to "Tune" - note that all tubes light.
 - c. () Turn "Meter" to "Buff" - note rise in current as "Drive" is advanced about 1/3 clockwise.
 - d. () Turn "Meter" to "Grid" - tune "Buffer" control for maximum grid current. Well over 4 ma. should be available when "Drive" is advanced. Set drive for 2.5 ma.
 - e. () Turn "Meter" to "Plt". Place the right hand on the "Final" control to locate it. Turn "Operate" to "Phone" and turn "Final" quickly until the dip in plate current is reached. Turn the "Auxiliary Coupling" until over 100 ma but less than 130 ma of plate current is noted, return "Final" and turn "Coupling" until 130 ma of plate current is noted. Retune the Final for dip again. A moderate spitting will be noted at the "Operate" switch when it is turned to or from the "Phone" position. This is harmless unless the switch is turned very slowly. Turn the operate switch without hesitating.
 - f. () Turn the "Meter" to "Grid", retune "Buffer", and adjust "Drive" for 2.5 ma grid current.
 - g. () Turn "Meter" to "Mod." The reading should be between 55 to 70 ma. If it is out of these limits, turn "Operate" to "Off", pull out the AC plug, discharge the rear terminal of the high voltage bleeder R35 to the chassis with an insulated screwdriver and adjust the tap of R35 carefully (loosening the tap

- U. 6. g. screw adequately to prevent breaking the resistance wire) toward the rear to increase the modulator current or toward the front to decrease it. Turn "Operate" to "Tune" for warmup and again to "Operate" to check the mod. current.
- h. () Plug in a crystal or a high impedance, communications type dynamic microphone into the two contact mike jack, J. The microphone plug should previously have been made up to correspond to J1 as shown in the schematic diagram, Figure 8. Turn the "Audio" control up and speak into the microphone. Upward modulation should be indicated by the load lamp becoming brighter when modulation is applied. Peak swings of 120 to 130 ma of plate current corresponds to 100 percent modulation.
- i. () Turn "Meter" to "Plt". Turn "Operate" to "Standby". Note that the VFO signal can be picked up by a receiver for zero beat purposes when the "Crystal-VFO" switch is turned to "Zero".
- j. () Turn "Crystal-VFO" to "VFO" and the "Operate" to "CW". The modulator current should be nearly zero. The "Plt" current indication on the meter should be between 30 and 50 ma. A high current indicates improper clamper tube operation. This current is primarily screen clamper current. Plug a key into the key jack, J2. Check the keying of the transmitter, noting that the plate current rises when the key is pressed.
- k. () Repeat steps d and e at the other end of the 40 meter band, 7.3 mc.
- l. () Turn "Operate" to "Tune" and "Crystal-VFO" to "XT2". Repeat tests of steps d, e and f.
- m. () Repeat tests of steps d, e and f for all bands (using a middle setting on the VFO) with the following three exceptions:
1. () Set "Crystal-VFO" on "Xt1" on the 80 and 160 meter bands.
 2. () Make the initial setting of "Auxiliary Coupling" "6" instead of "1" on 20, 15, 10 and 11 meters. This is important on the 15, 10 and 6 meter bands.
 3. () The grid drive on 10 and 6 meters may be initially low until the L5 slug is adjusted. Peak the grid current at the vicinity of 28 mc by turning the L5 slug.
7. () Keyer control adjustment.
- a. () Couple the VFO output to a receiver.
 - b. () Close key and tune receiver to VFO signal.
 - c. () Open key.
 - d. () Turn VFO keyer adjust control, R39, counter-clockwise until VFO signal starts.
 - e. () Turn VFO keyer adjust control clockwise just slightly beyond the point at which the VFO signal stops. Adjustment in the extreme clockwise position may cut off the VFO too soon and result in "squaring" or "sharpening" of the keying envelope at the break with attendant clicks.
8. () Calibrate the VFO as instructed in Section E of the Operating Manual for the Viking Ranger. The following suggestions apply if difficulty is experienced in tracking the VFO:

- U. 8. a. () Check the calibrating standard settings carefully. If crystals are used, check the crystal frequencies carefully before attempting further calibration. Make certain that the receiver used is tuned to the proper signal rather than an image.
- b. () Recheck the meshing to the VFO condenser with the left side horizontal position of the dial pointer.
- c. () If the C2 trimmer or C3 padder are in position indicating that less capacity is required, the end turns of the spaced wound 40 meter VFO coil may be spread and recemented.
- d. () If the C5 trimmer or C6 padder are in a position indicating that less capacity is required, the end turns of the close wound 160 Meter VFO coil may be pushed away from the coil and recemented.
- e. () If any trimmer or padder appears to require more capacity a 5, 6, 8 or 10 mmf low temperature coefficient, tubular ceramic silvered or mica condenser may be connected across the trimmer. These condensers are not supplied with the kit as they will very rarely be needed.
9. () Readjust L5 for maximum grid current at 28 mc.
10. () Adjust L37 for maximum grid current at 51 mc on the 6 meter band.

V. CABINET ASSEMBLY.

1. () Attach the two rails and the four mounting feet to the bottom (the side with four holes) of the cabinet as indicated in Figure 10C. The slanting side of each rail must be oriented toward the rear side of the cabinet.
2. () Place a #10 external tooth shakeproof on each of the three 1 3/8" tie bolts and insert the tie bolts in the upper holes of the cabinet on through the support brackets near the front.
3. () Place the back of chassis on the front of the cabinet rails and slide the chassis in the cabinet, pulling the power cord through the rear cutout.
4. () Engage the three tie rods in the front panel strip tapped holes and pull up the tie rods until the panel nearly covers the front cabinet offset.
5. () Secure the chassis to the rear of the cabinet with the eight 1/2" 10-24 (or 10-32) truss head screws and eight #10 external shakeproof washers. Lubricate each of the eight holes with a little vasoline or similar lubricant before self tapping the thread at each hole. Draw up the tie bolts until the panel covers the cabinet offset evenly.
6. () A small ceramic plug, P2, will be found unused after the assembly is completed. Save this plug for later relay connection to J4 if an antenna relay is installed.

Refer to the Operating Manual for circuit descriptions, operating instructions and typical voltage, current and resistance values.

NOTE: Excess hardware, wire, etc., is supplied in the RANGER II kit. Do not worry about these excess items if the Assembly instructions have been rigorously followed.

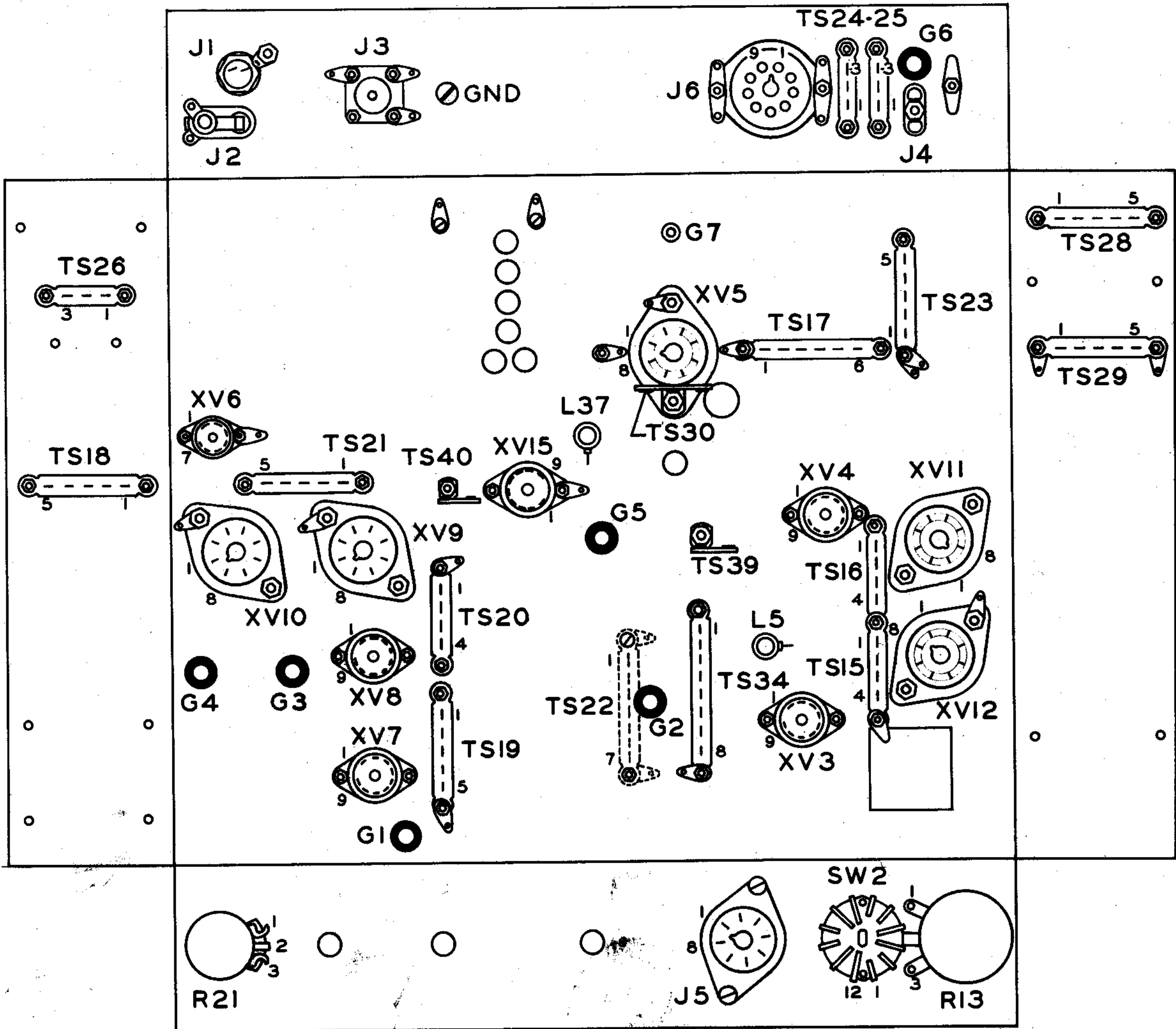

FIG. 1A-BOTTOM VIEW OF CHASSIS
SIDES FOLDED OUTWARD

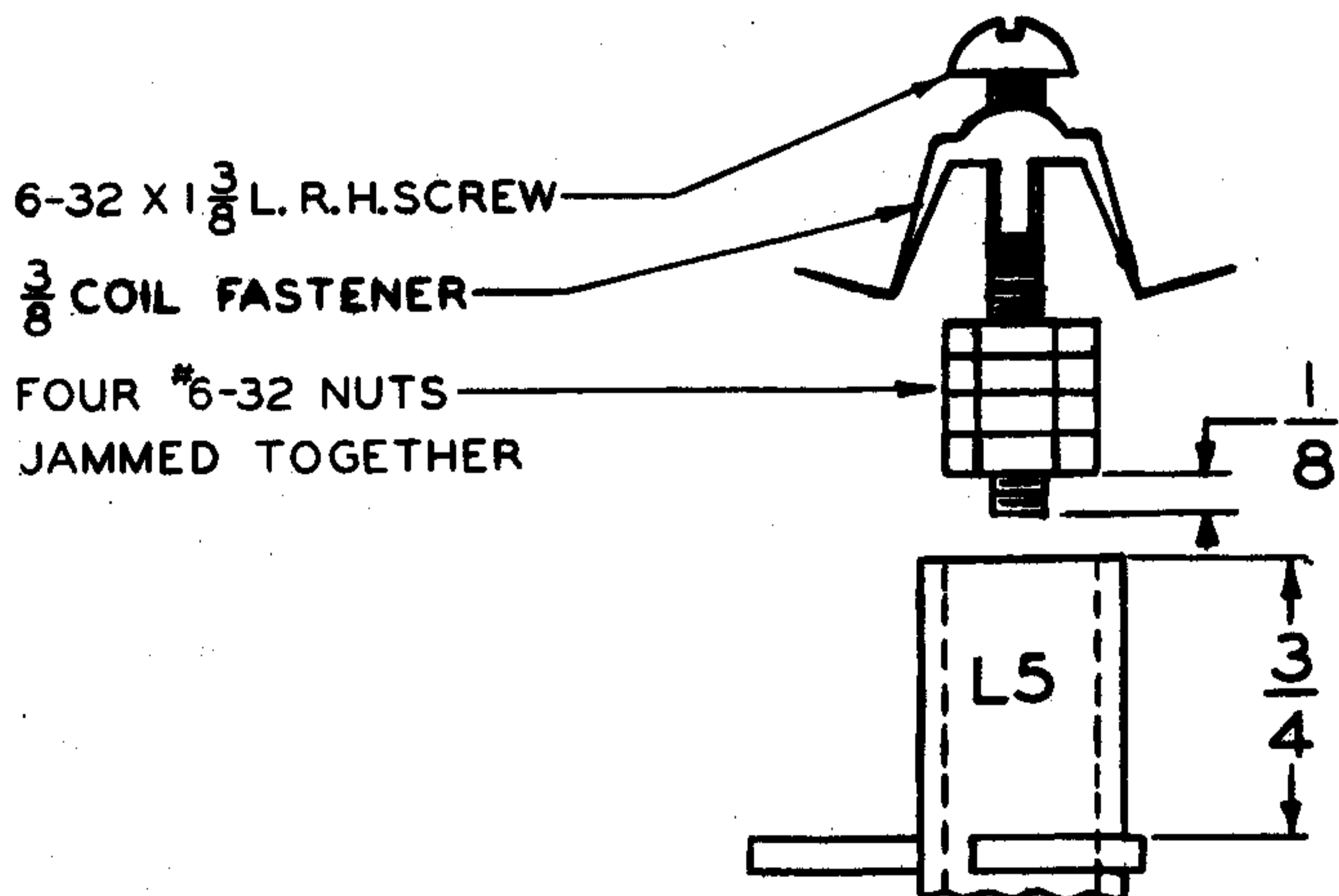
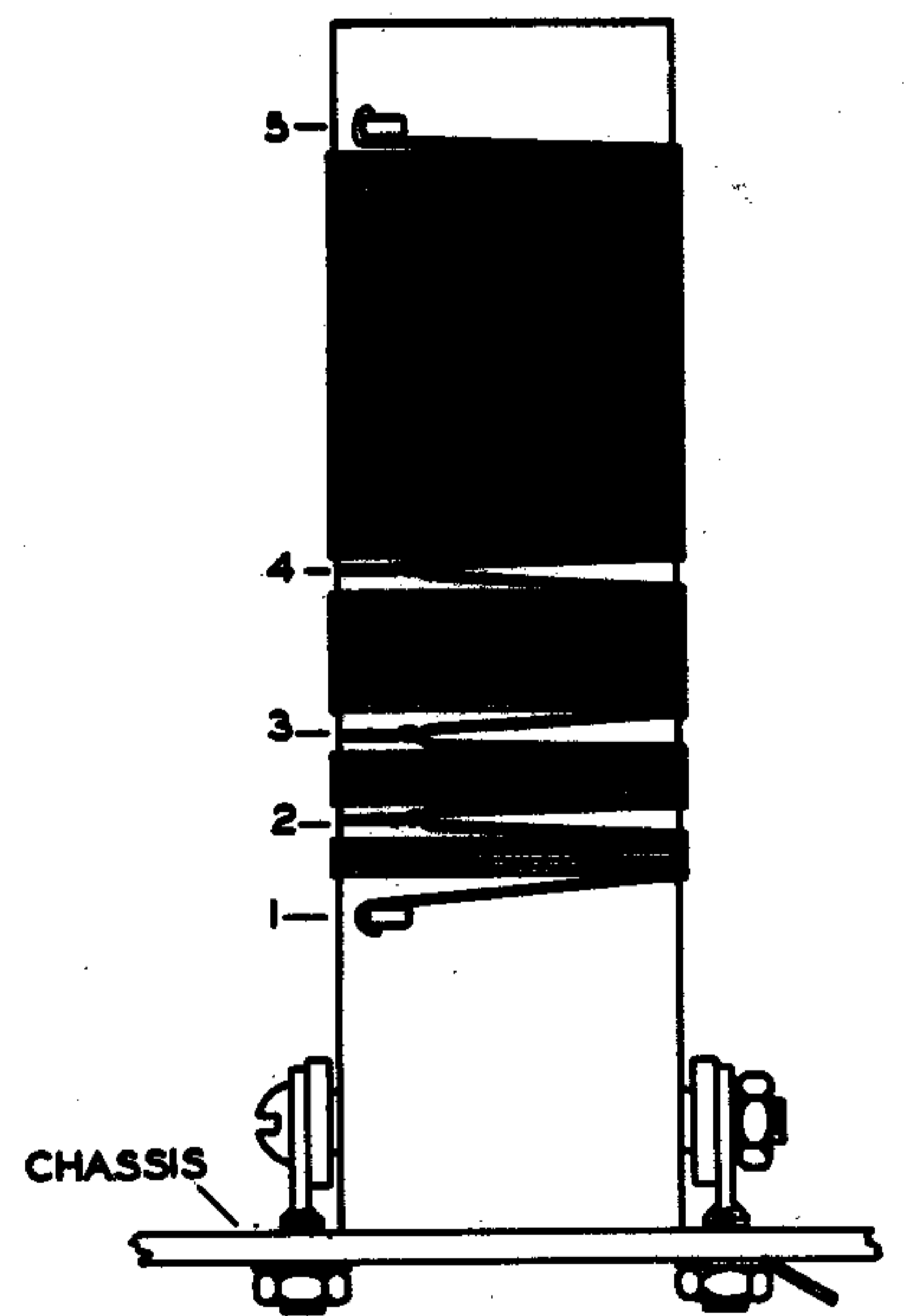

FIG. 1B OSC. COIL L5
FASTENER ASSEMBLY



COIL L6A
FIGURE 1C

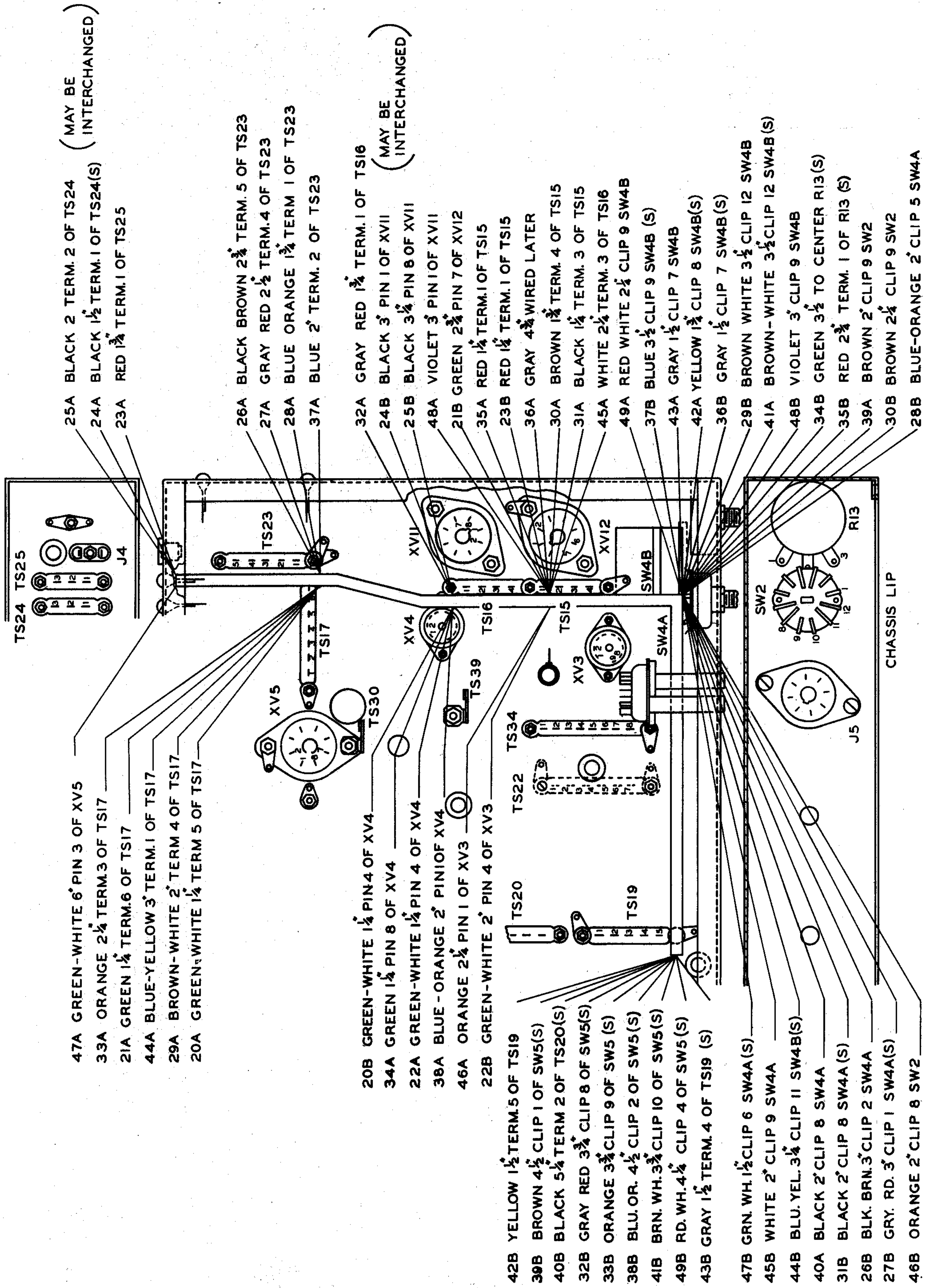

FIG. 2 R.F. SECTION HARNESS

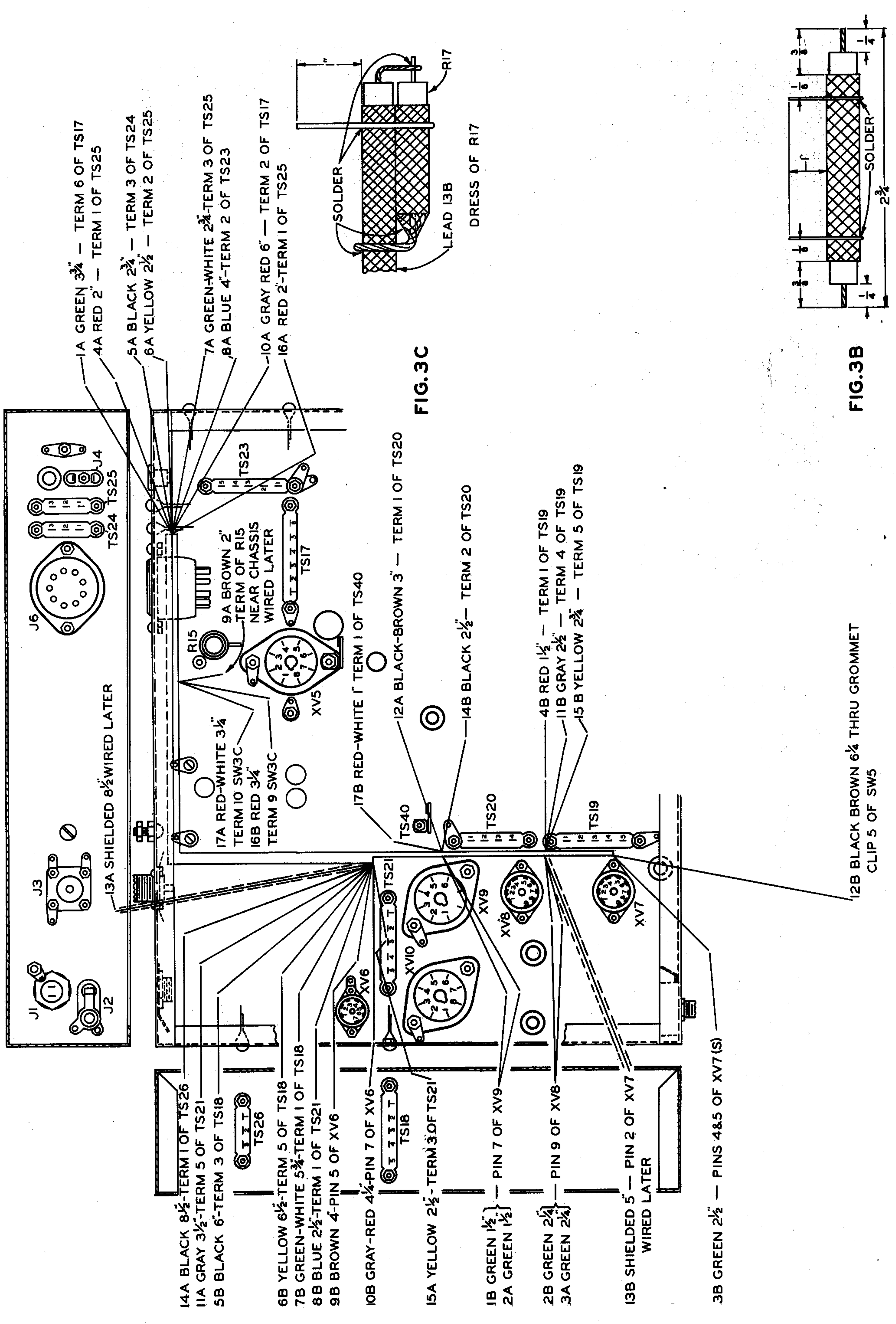

FIG. 3C

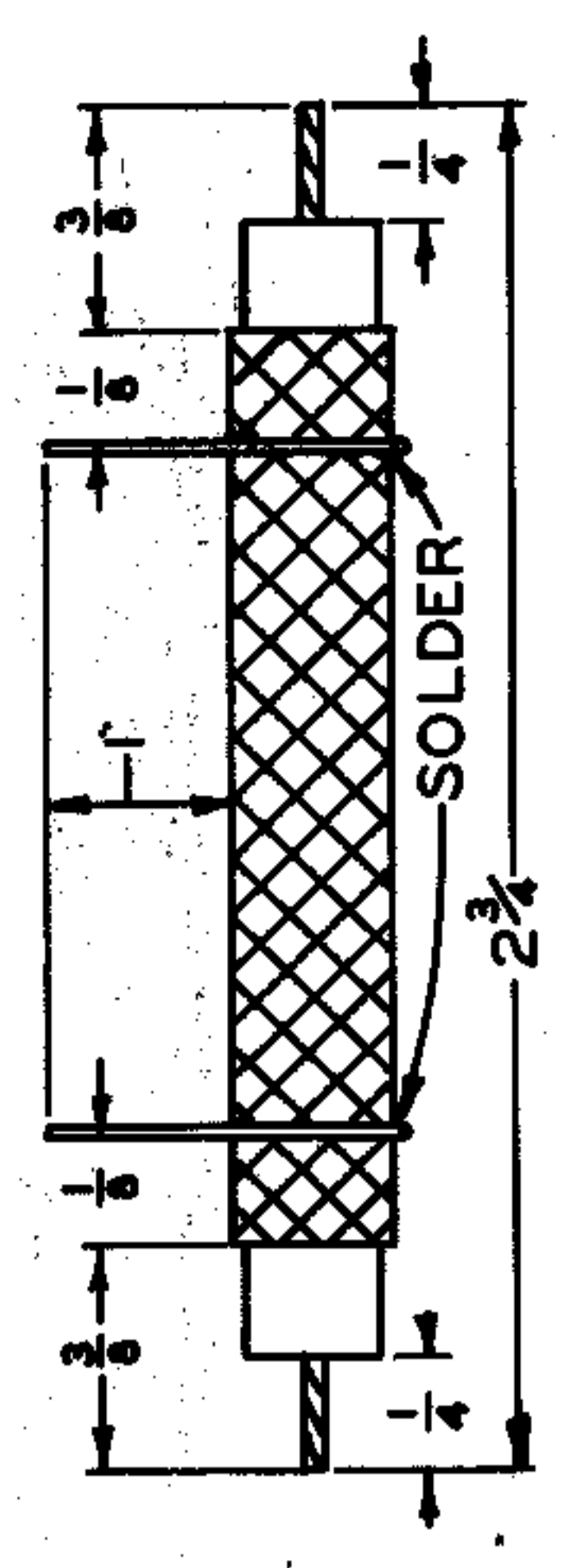

FIG. 3B

FIG. 3A AUDIO SECTION HARNESS

AUDIO CONTROL LEAD

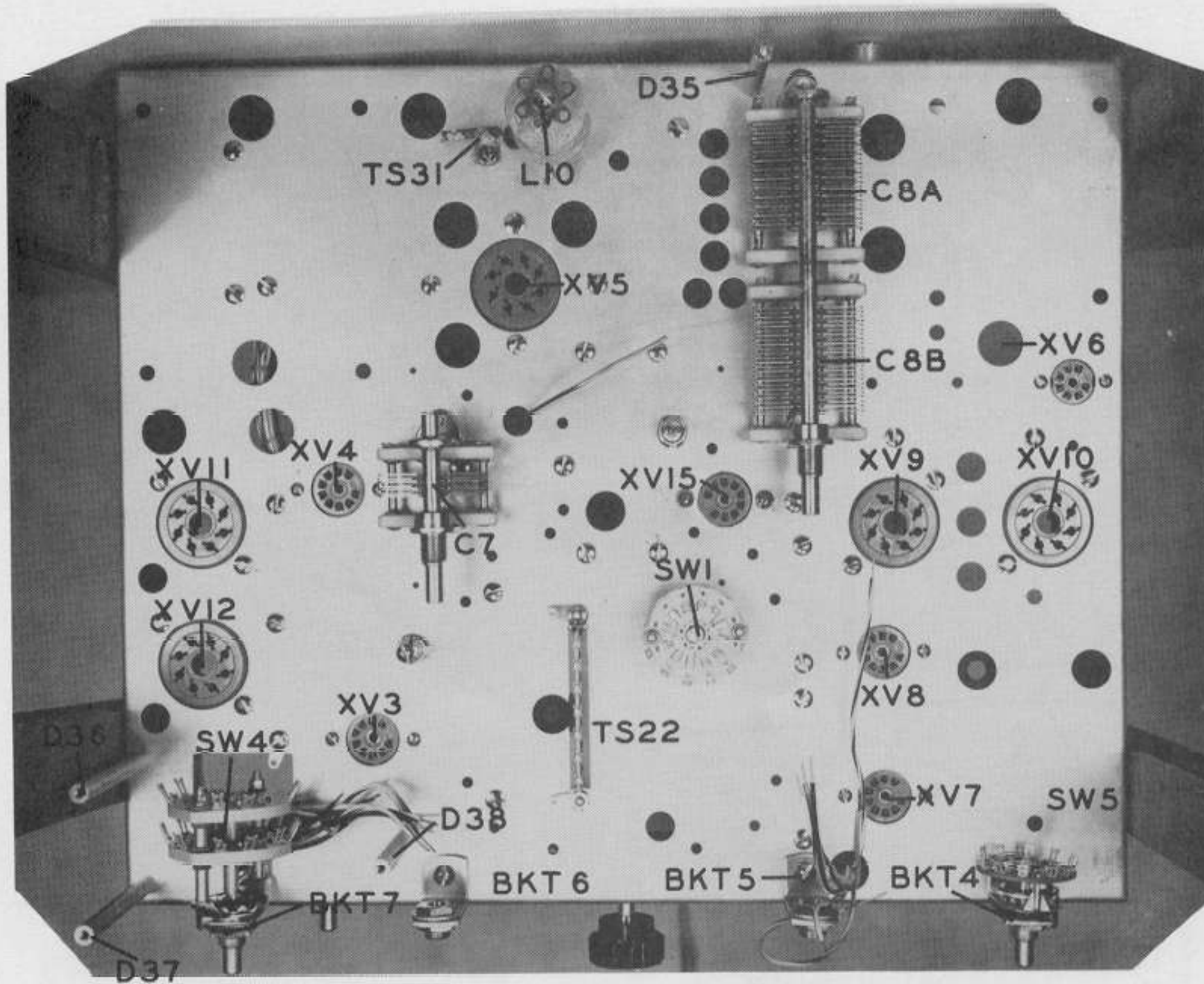

FIGURE 4A-TOP CHASSIS
COMPONENT MOUNTING

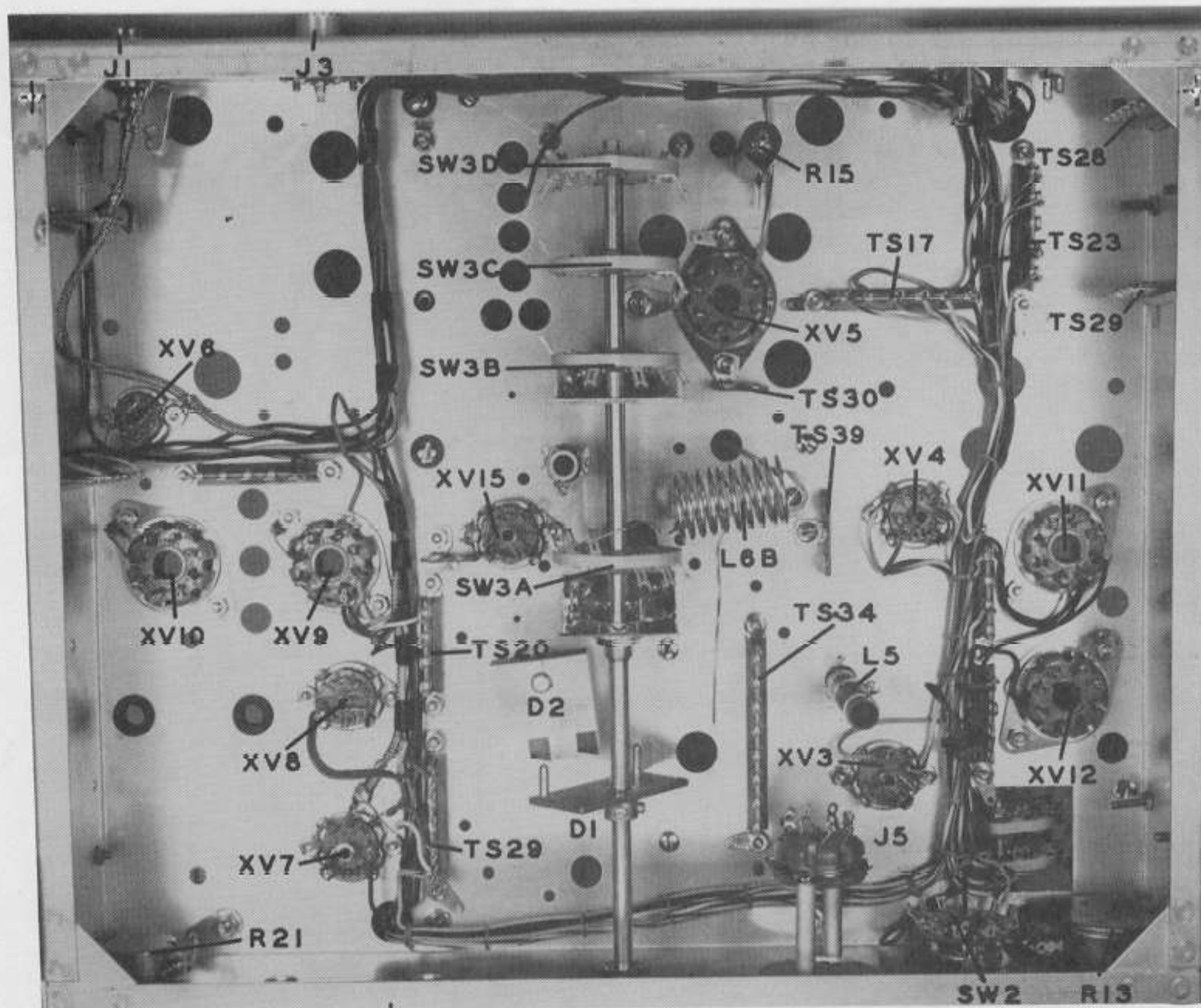

FIGURE 4B-BOTTOM CHASSIS
COMPONENT MOUNTING

FRONT OF CHASSIS

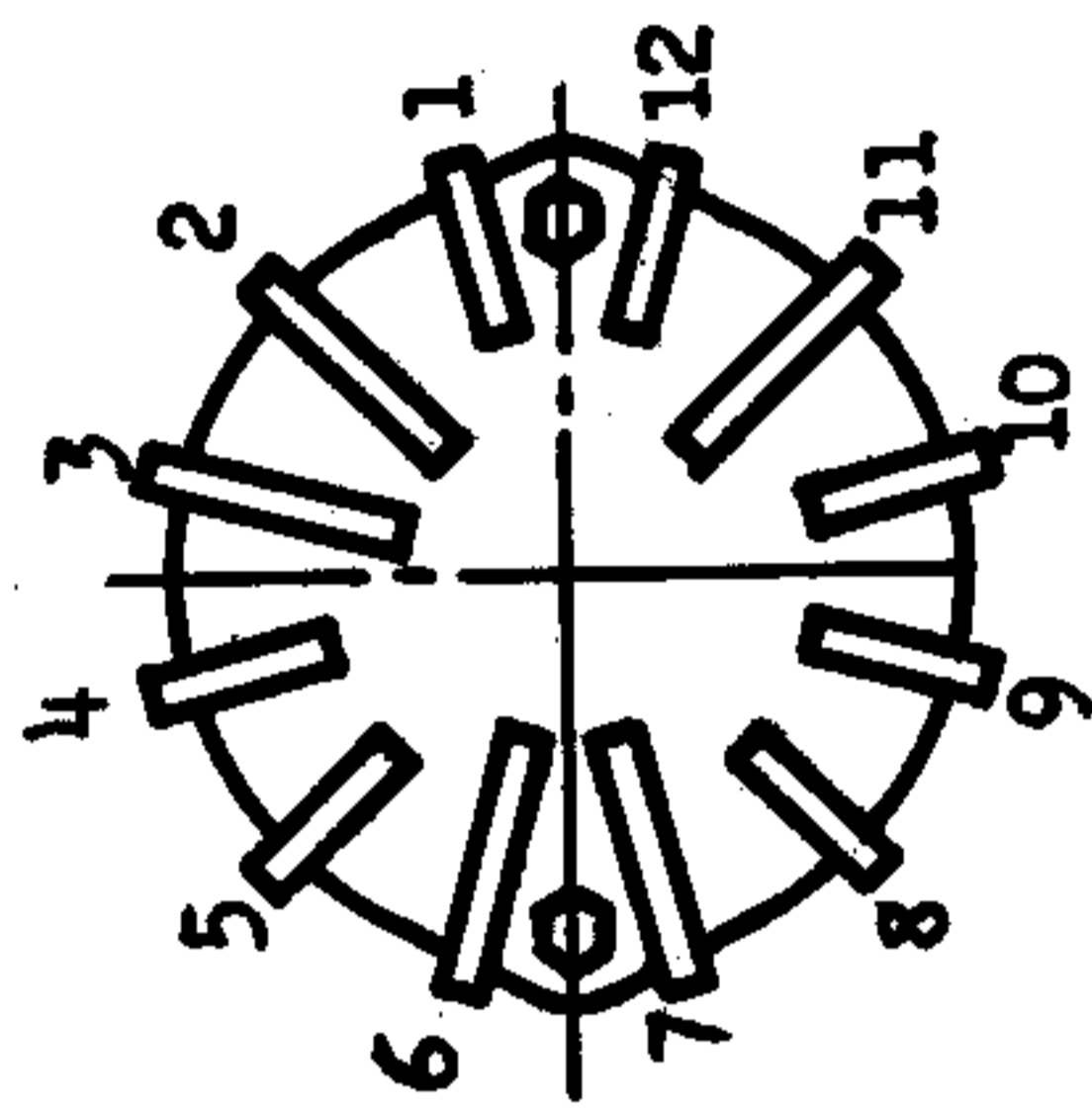

FIG. 5C. SW1, V.F.O. BANDSWITCH TOP VIEW

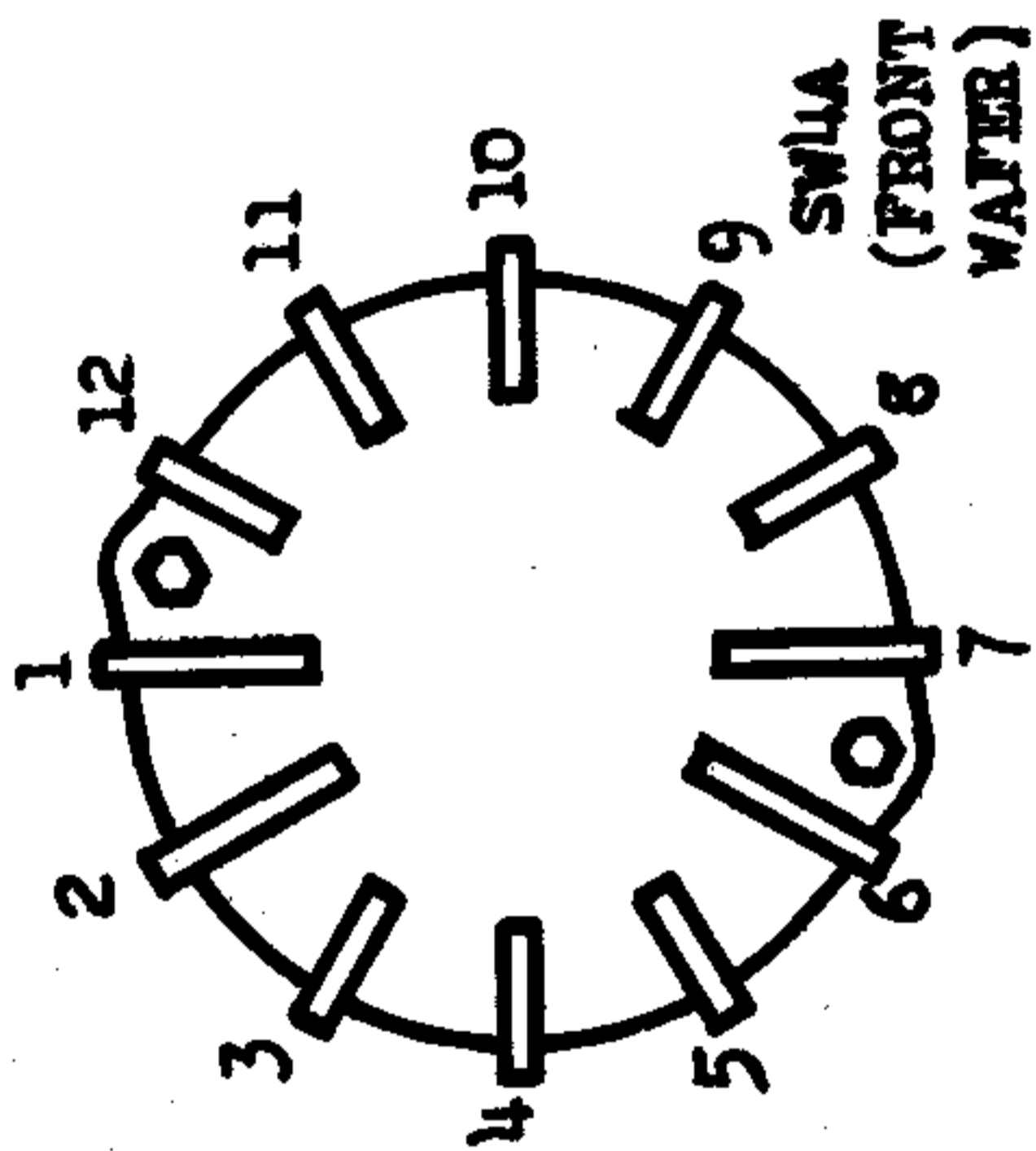

FIG. 5A. SW5, METER SWITCH, REAR VIEW

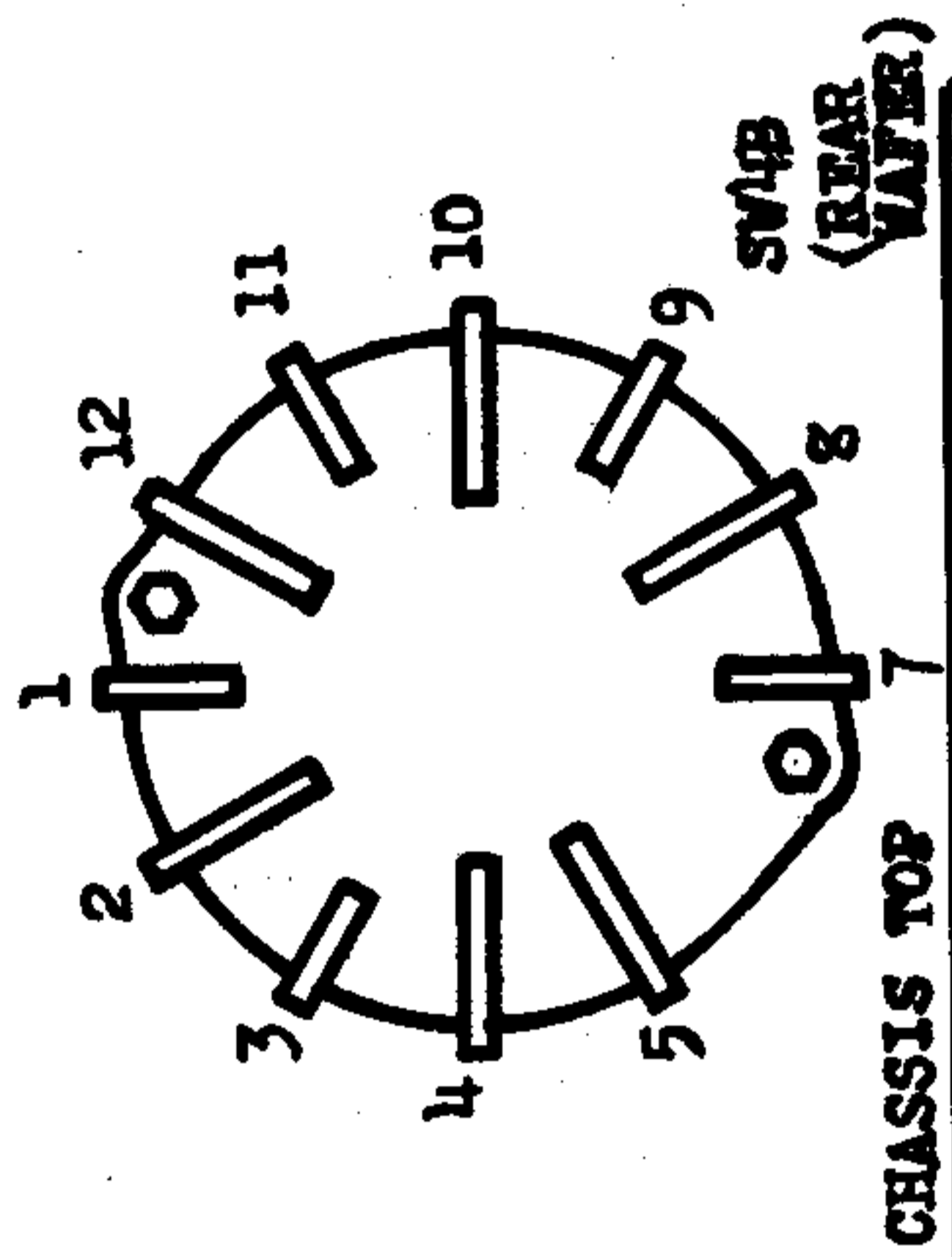

FIG. 5B. SW4, OPERATE SWITCH REAR VIEW

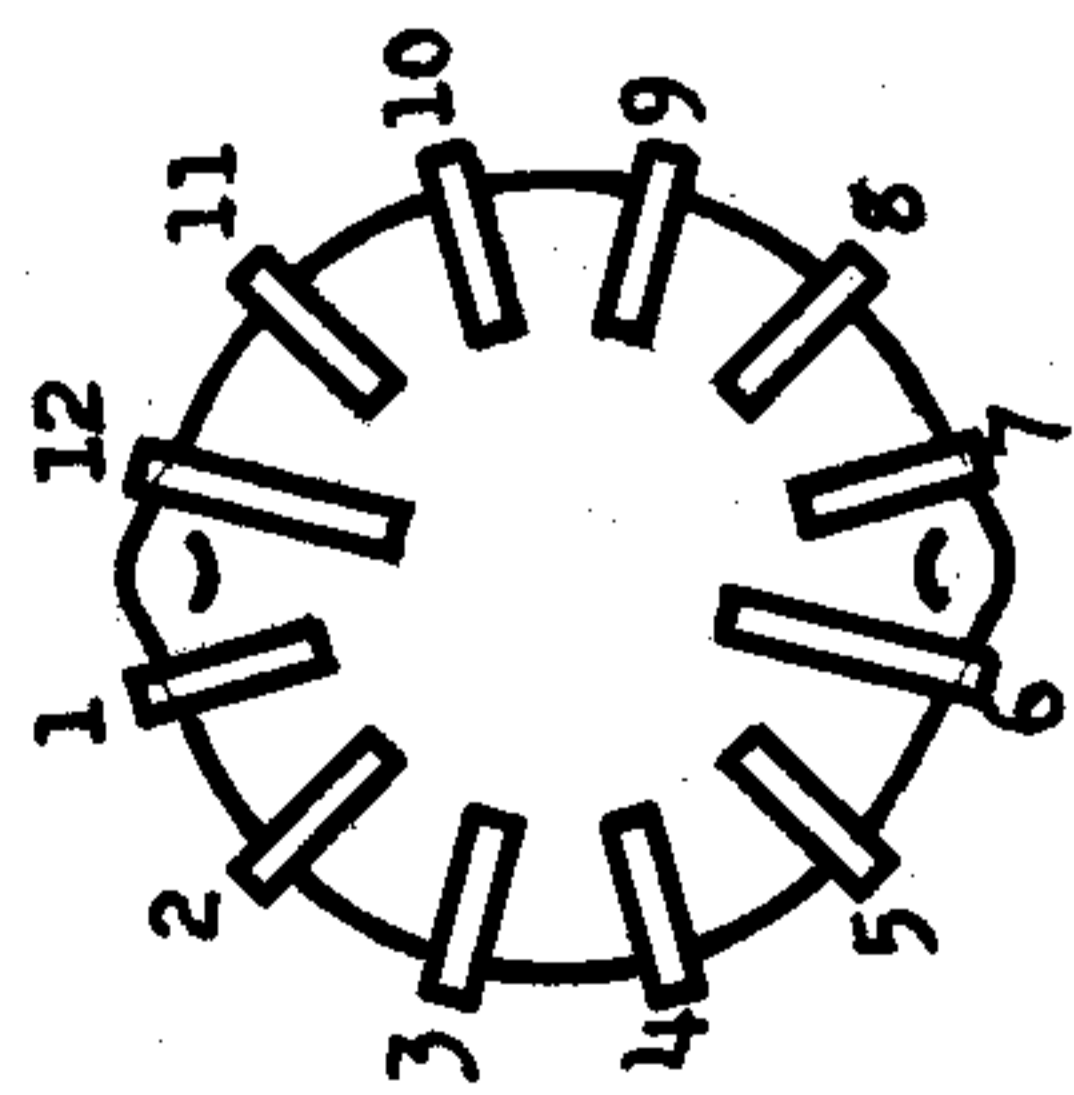

FIG. 5D. SW6, COUPLING SWITCH, REAR VIEW. BOTTOM SIDE OF CHASSIS UP

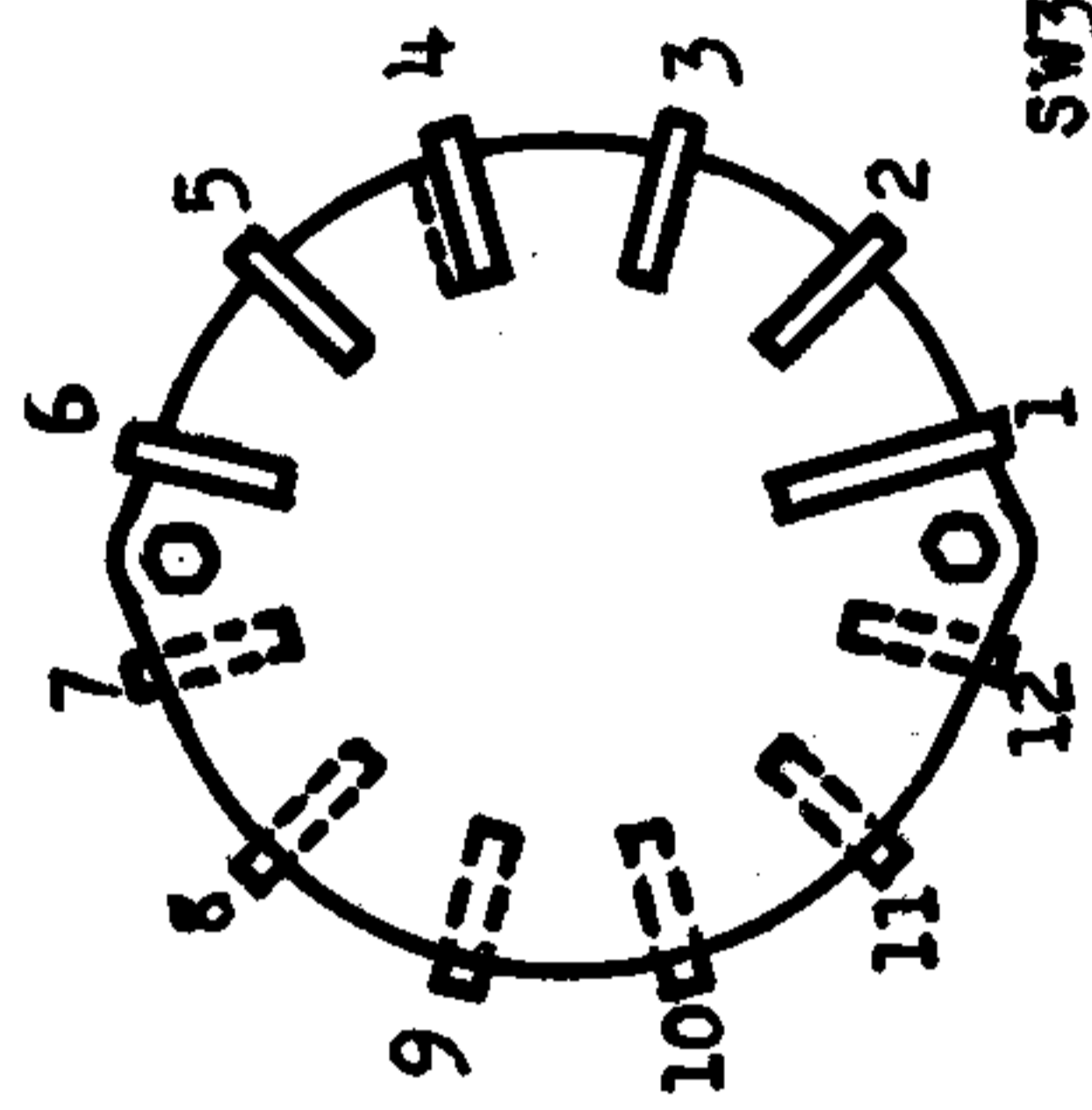

FIG. 5E. SW3, BANDSWITCH, REAR VIEW. BOTTOM SIDE OF CHASSIS UP

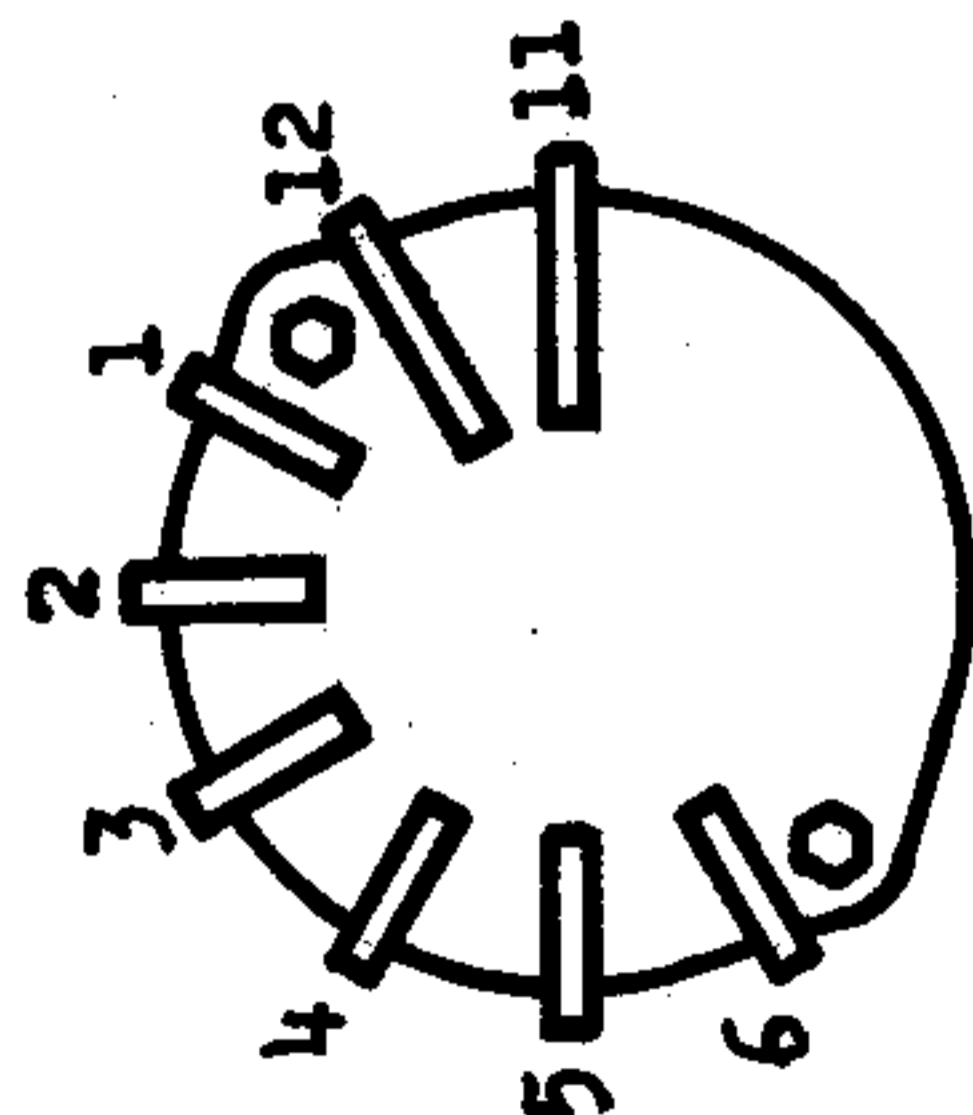

FIG. 5F. TEMPORARY MOUNTING LEGS

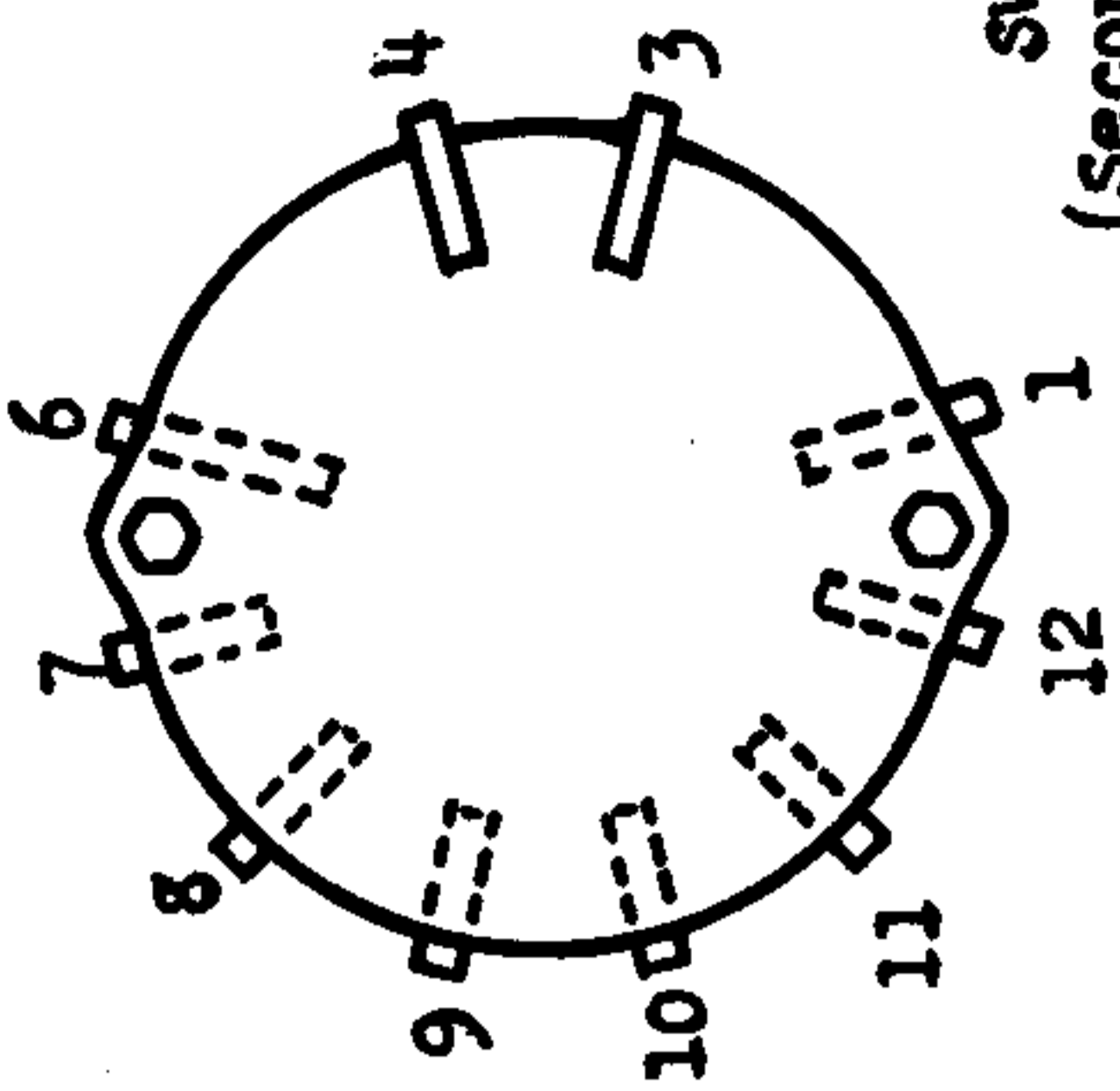

FIG. 5E. SW3, BANDSWITCH, REAR VIEW. BOTTOM SIDE OF CHASSIS UP

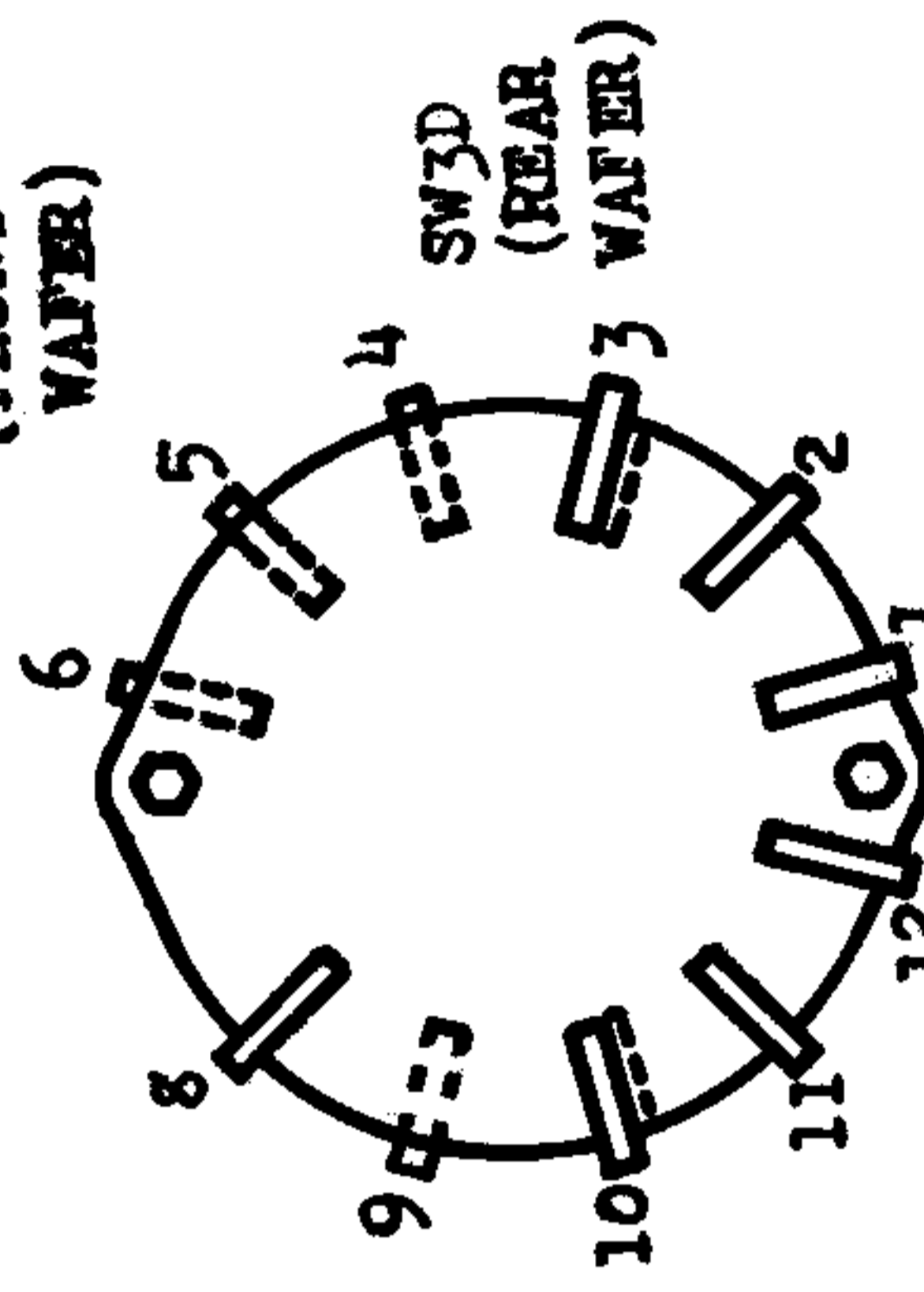

FIG. 5E. SW3, BANDSWITCH, REAR VIEW. BOTTOM SIDE OF CHASSIS UP

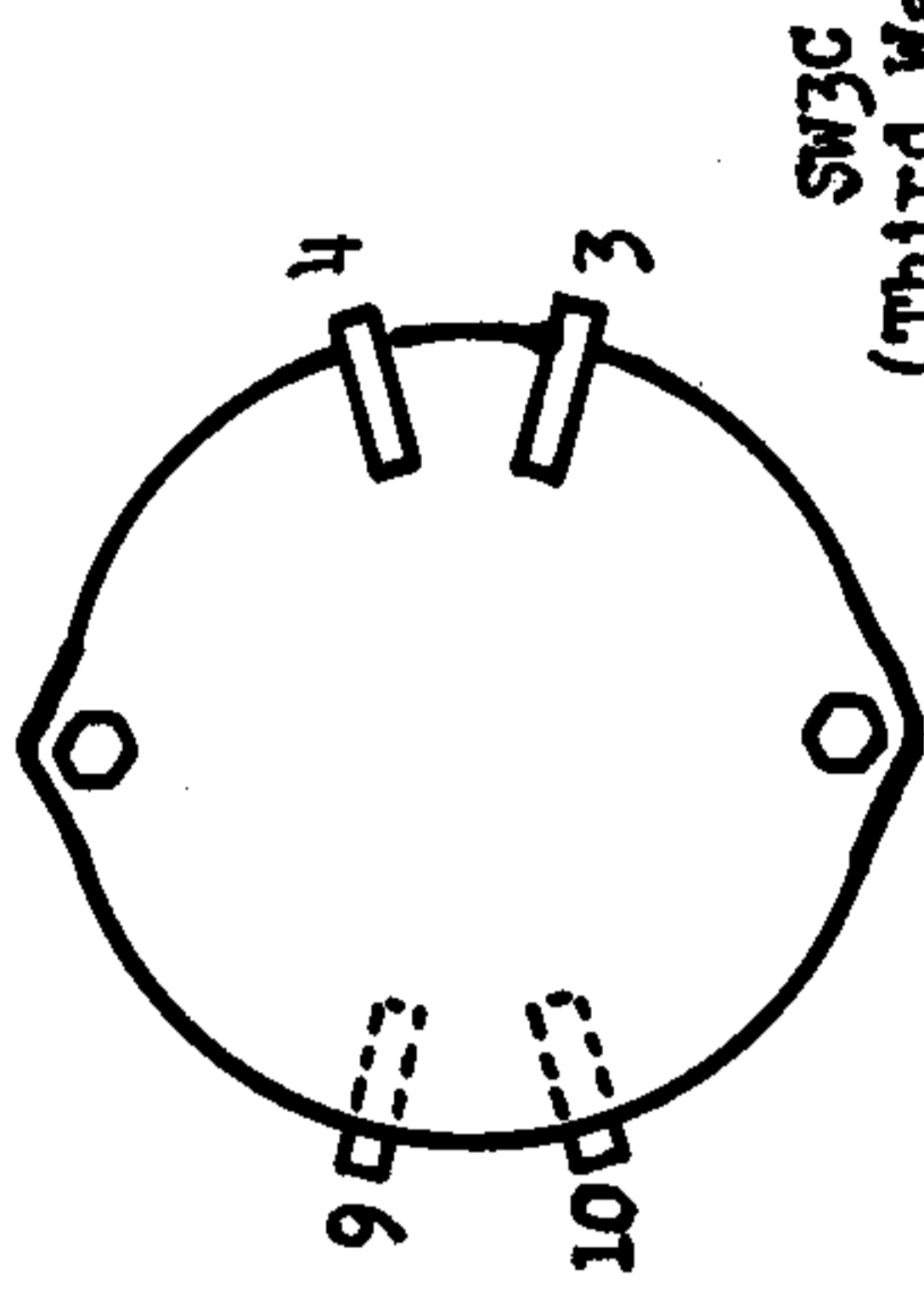

FIG. 5E. SW3, BANDSWITCH, REAR VIEW. BOTTOM SIDE OF CHASSIS UP

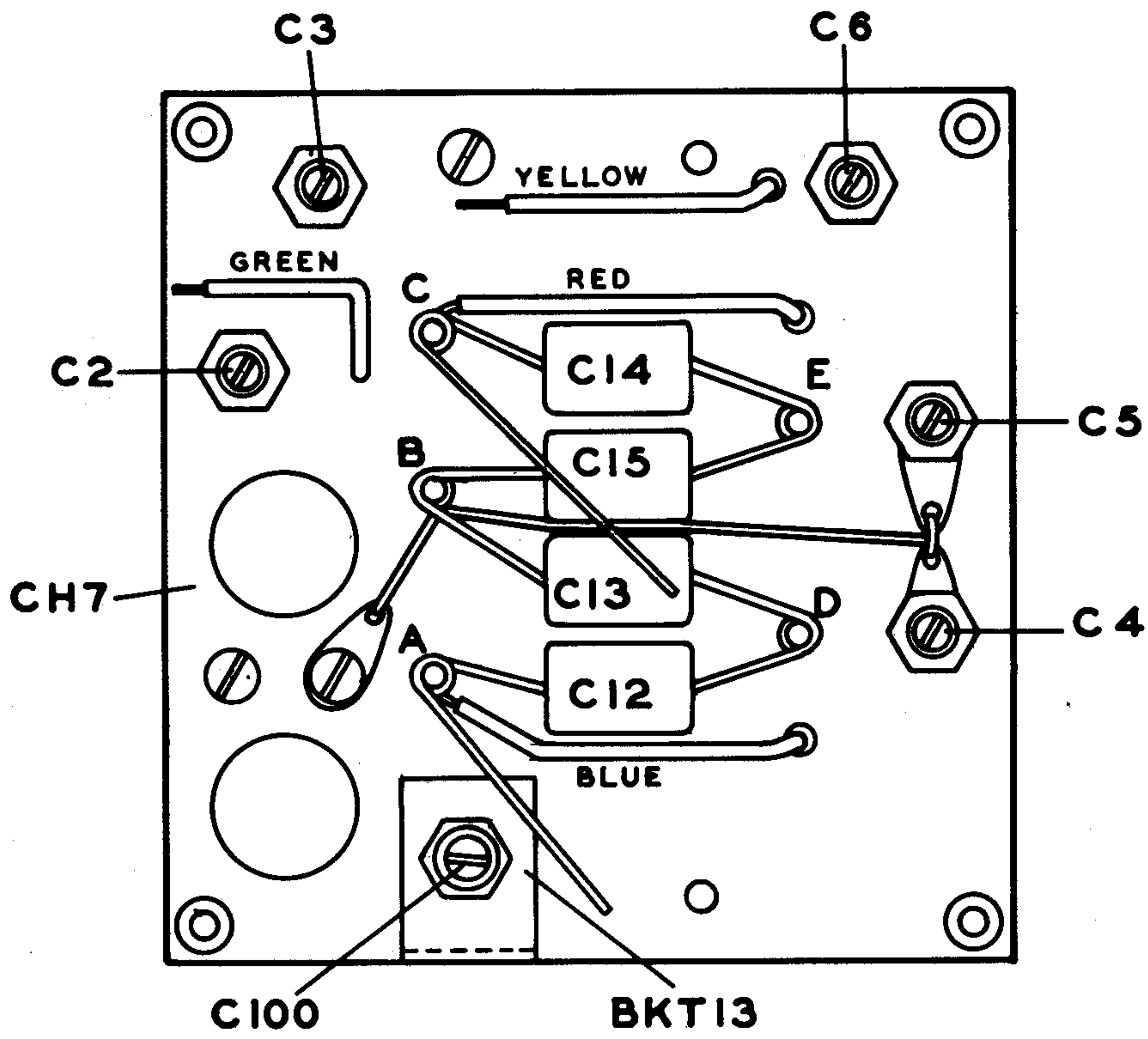

FIGURE 6A VFO-TOP VIEW

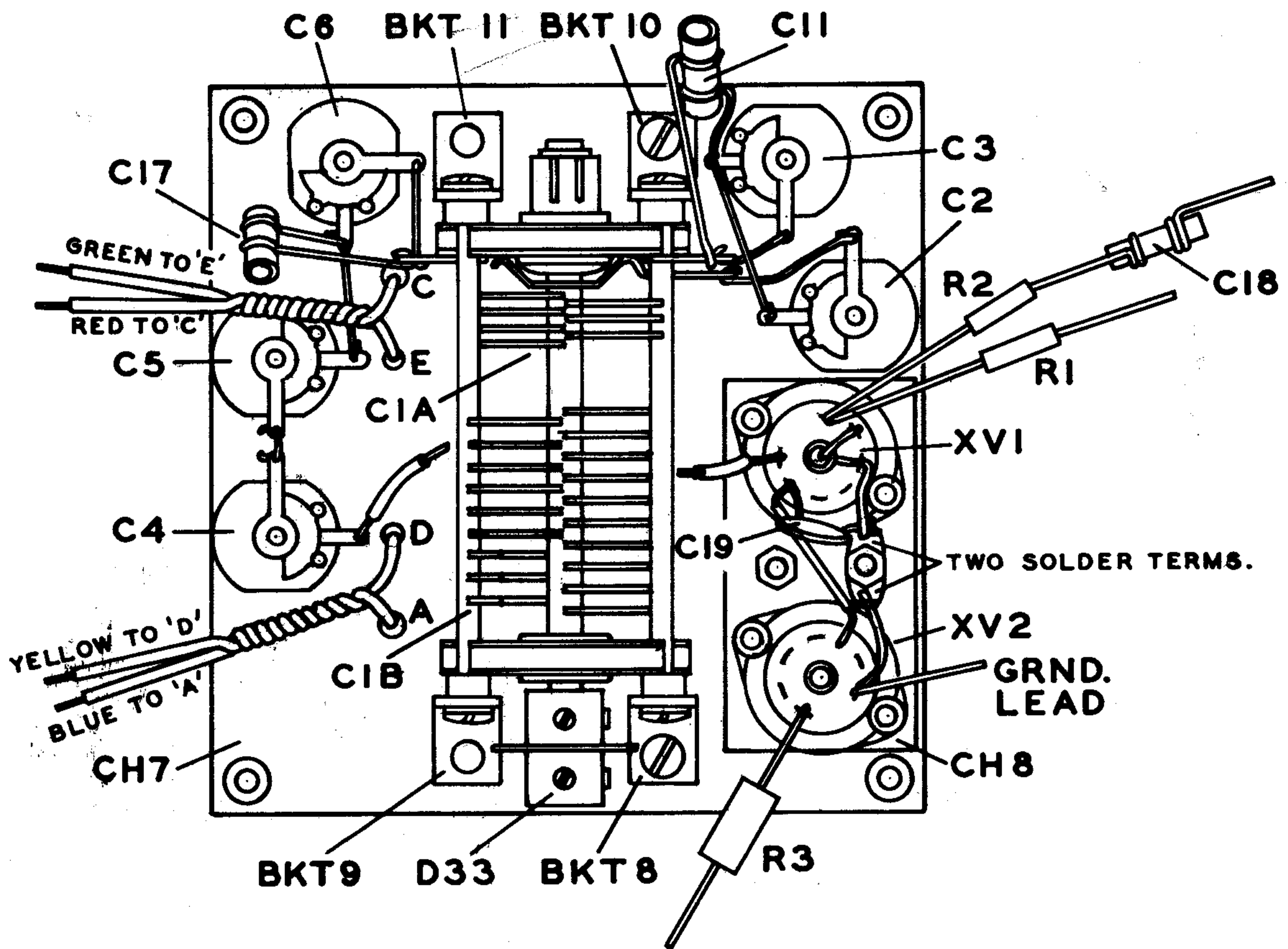

FIGURE 6B VFO-BOTTOM VIEW

FIGURE 7A VFO LEFT VIEW

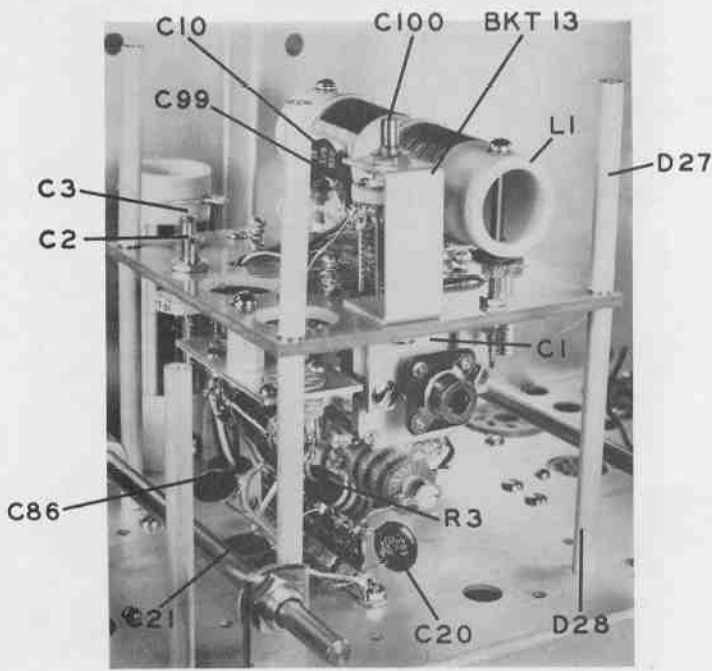

FIGURE 7A VFO RIGHT VIEW

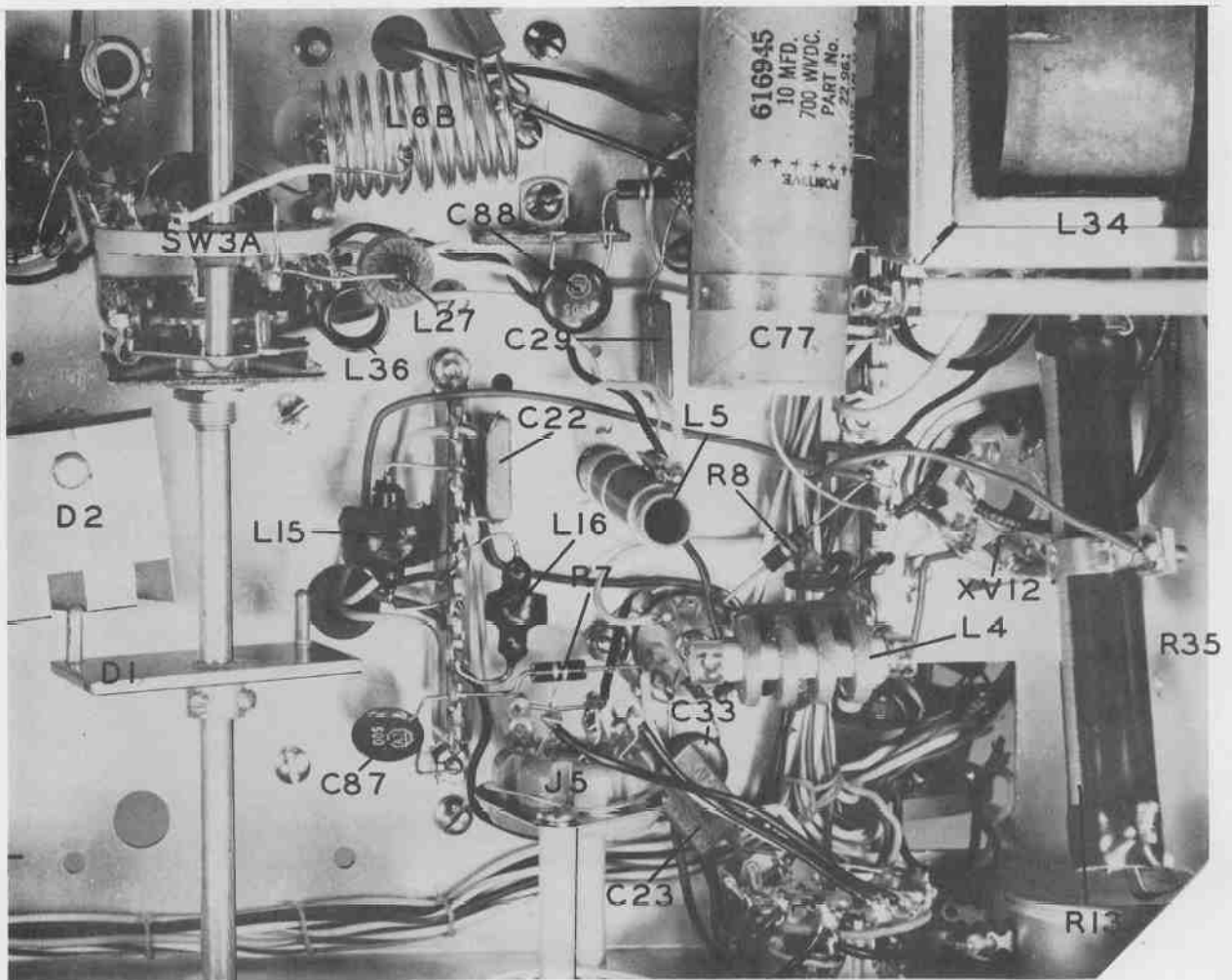
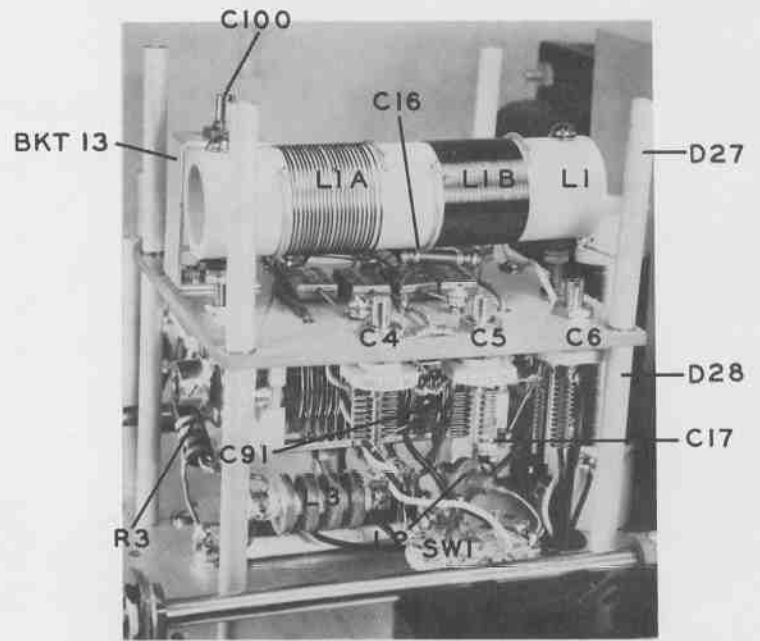

FIGURE 7B - R.F. EXCITER SECTION
BOTTOM VIEW

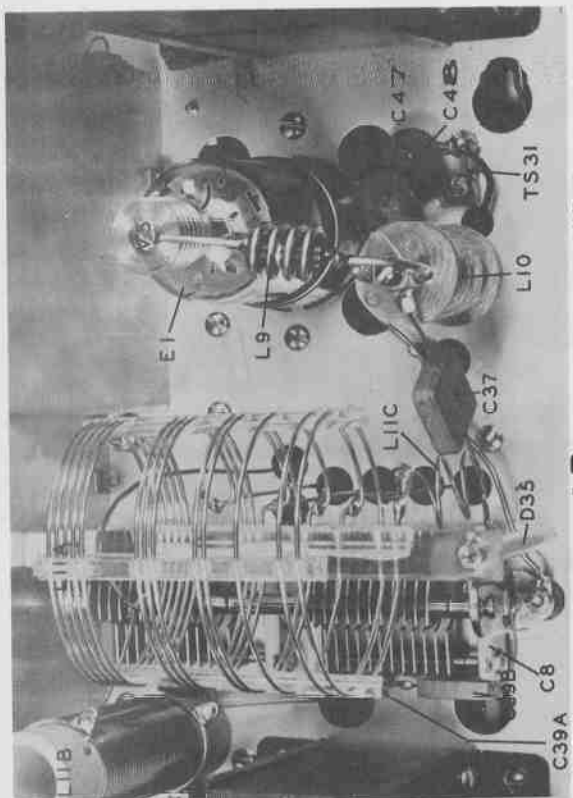

FIGURE 8B RRF FINAL TOP VIEW

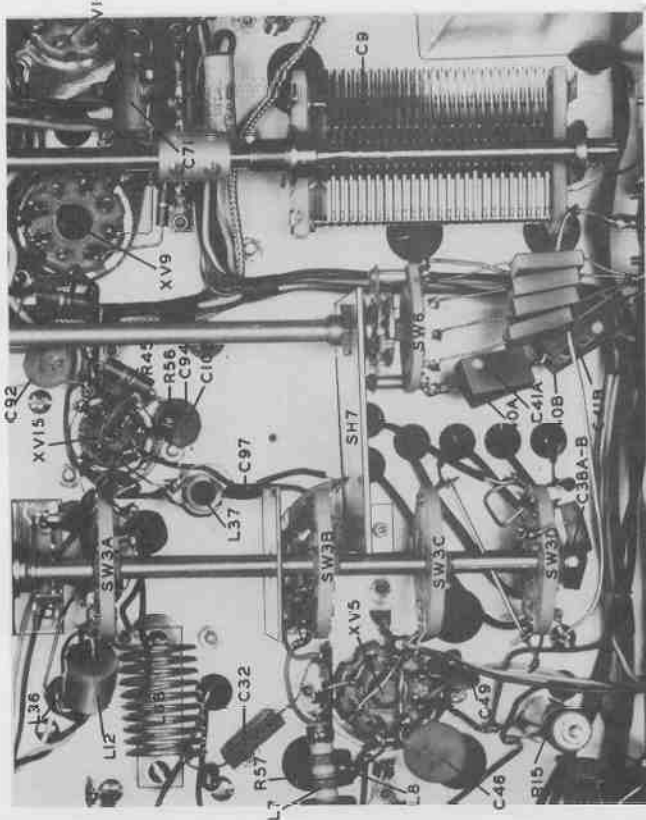

FIG 8C-RF FINAL BOTTOM VIEW

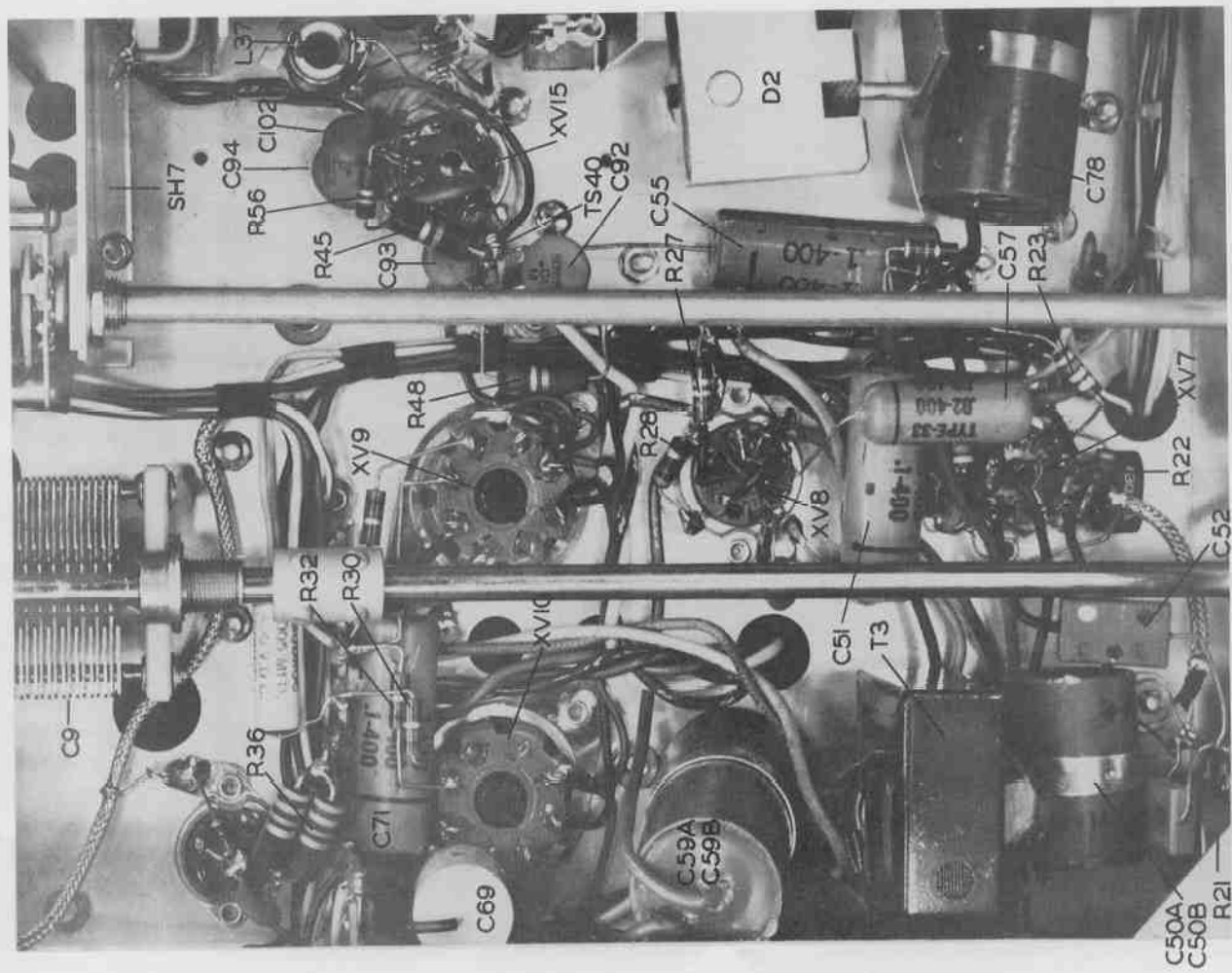

FIG. 8A
AUDIO SECTION

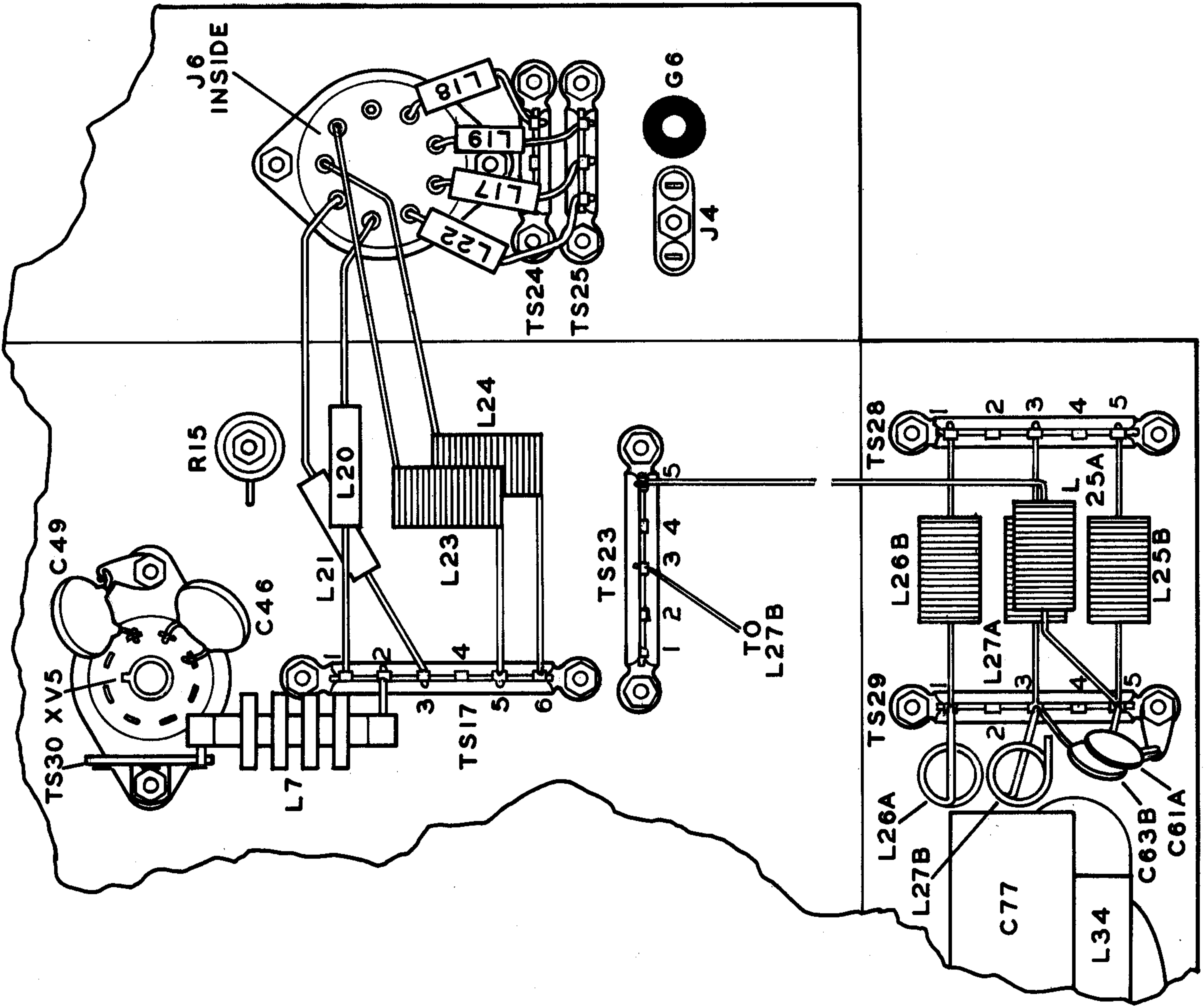

FIGURE 9A LINE FILTER-AUXILIARY SOCKET
(UNFOLDED VIEW)

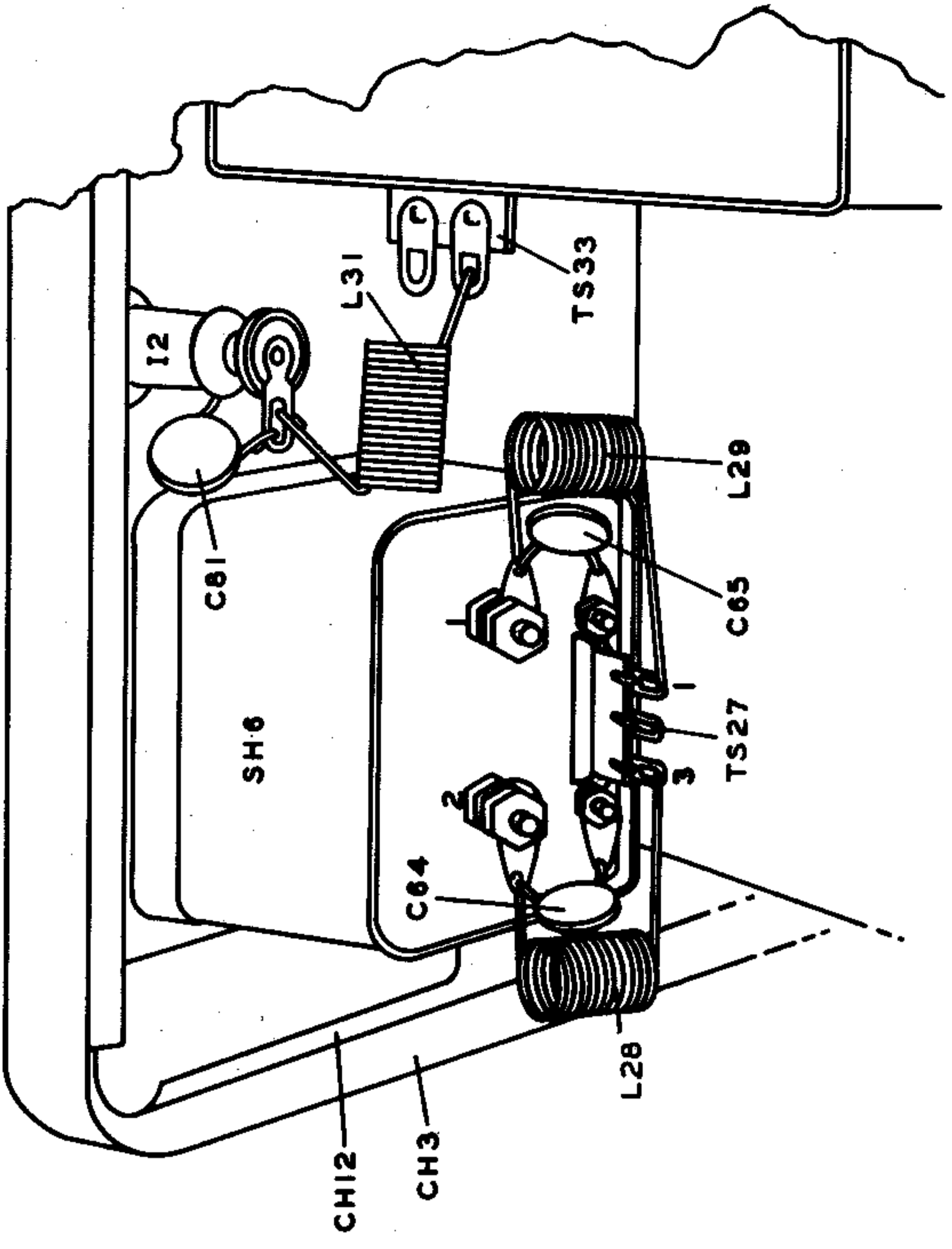

FIGURE 9B-METER SHIELD

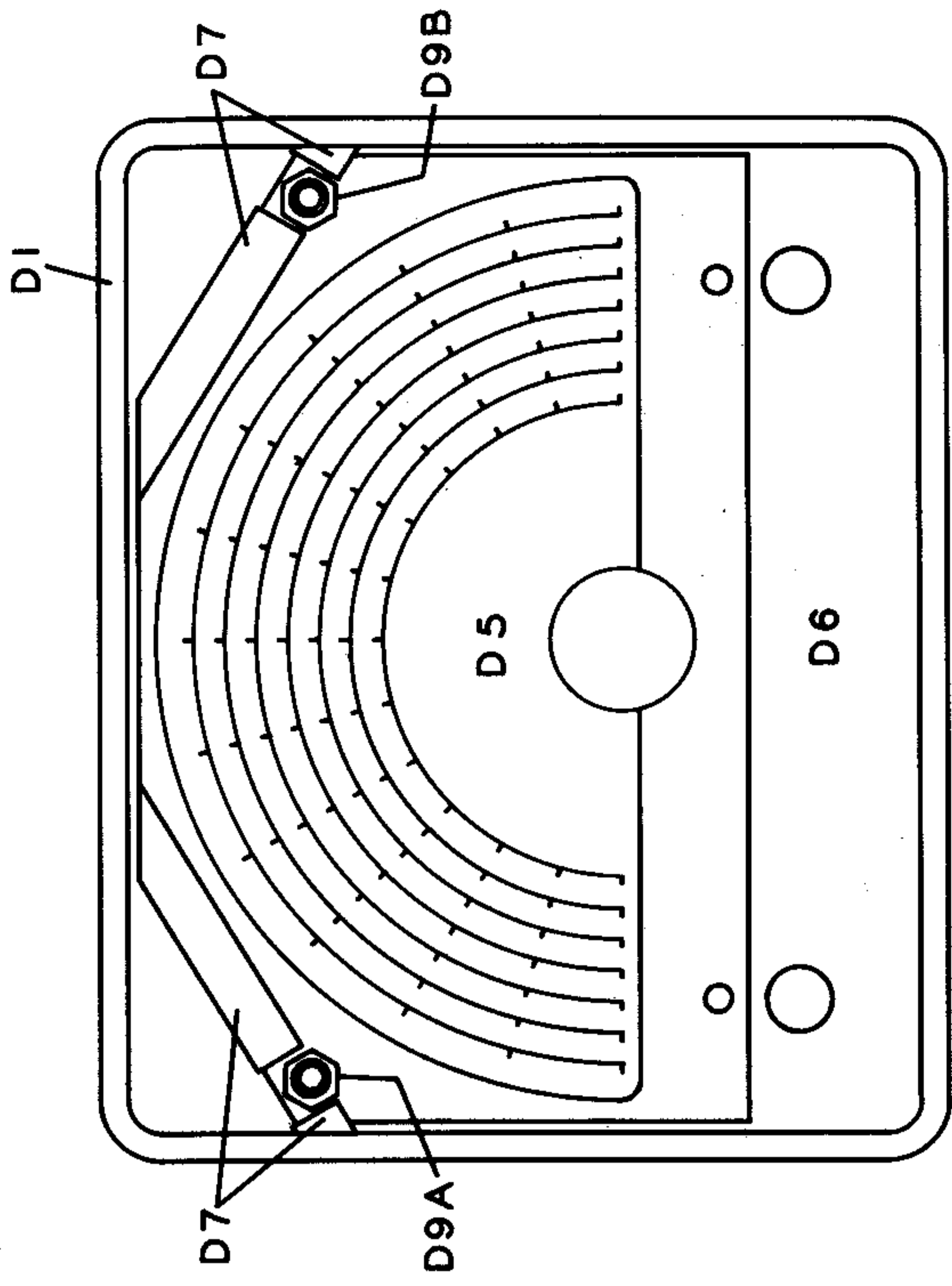

FIGURE 9C-ESCUTCHEON AND DIAL
(REAR VIEW)

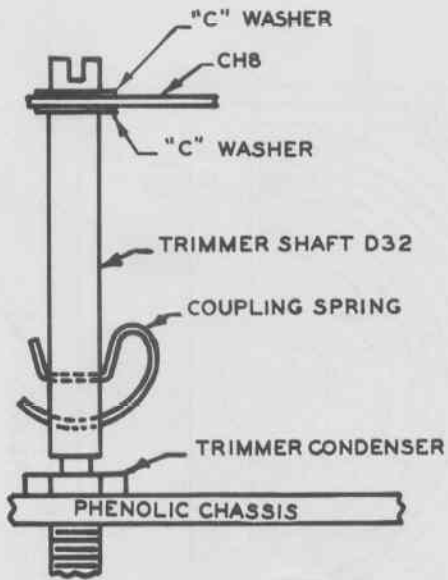

FIG. 10A. V.F.O. TRIMMER SHAFT ASSEMBLY

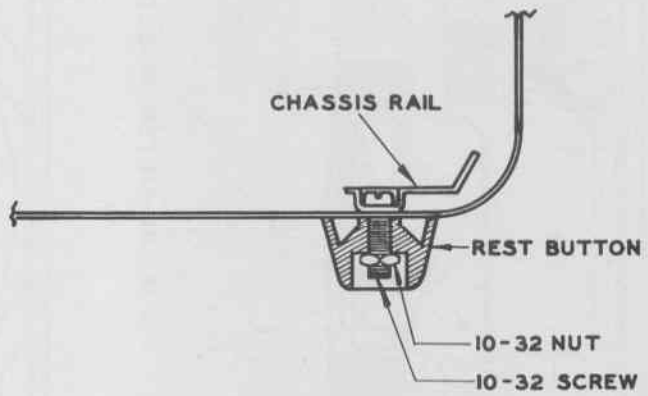
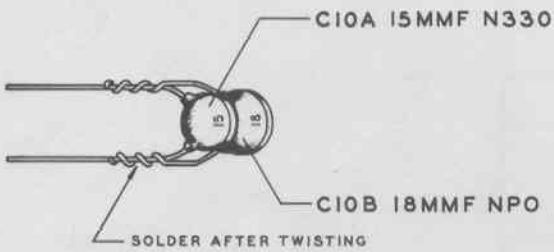
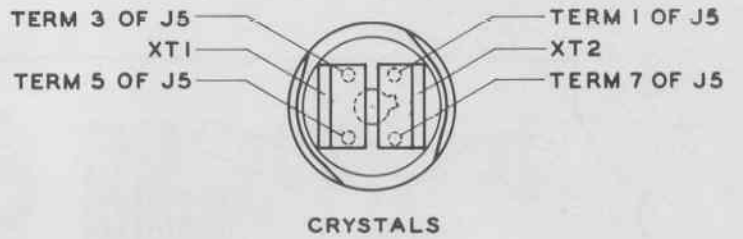

FIG. 10C. CABINET, RAIL, AND FOOT ASSEMBLY



C10A-B CAPACITOR ASSEMBLY



FRONT PANEL

FIGURE 10D-CRYSTAL SOCKET

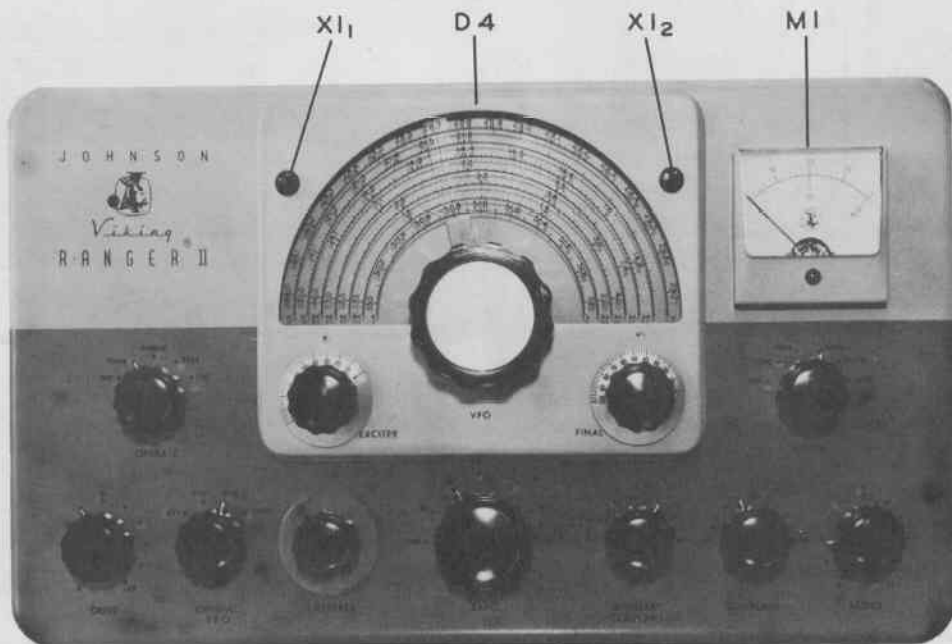

FIGURE 10E FRONT PANEL

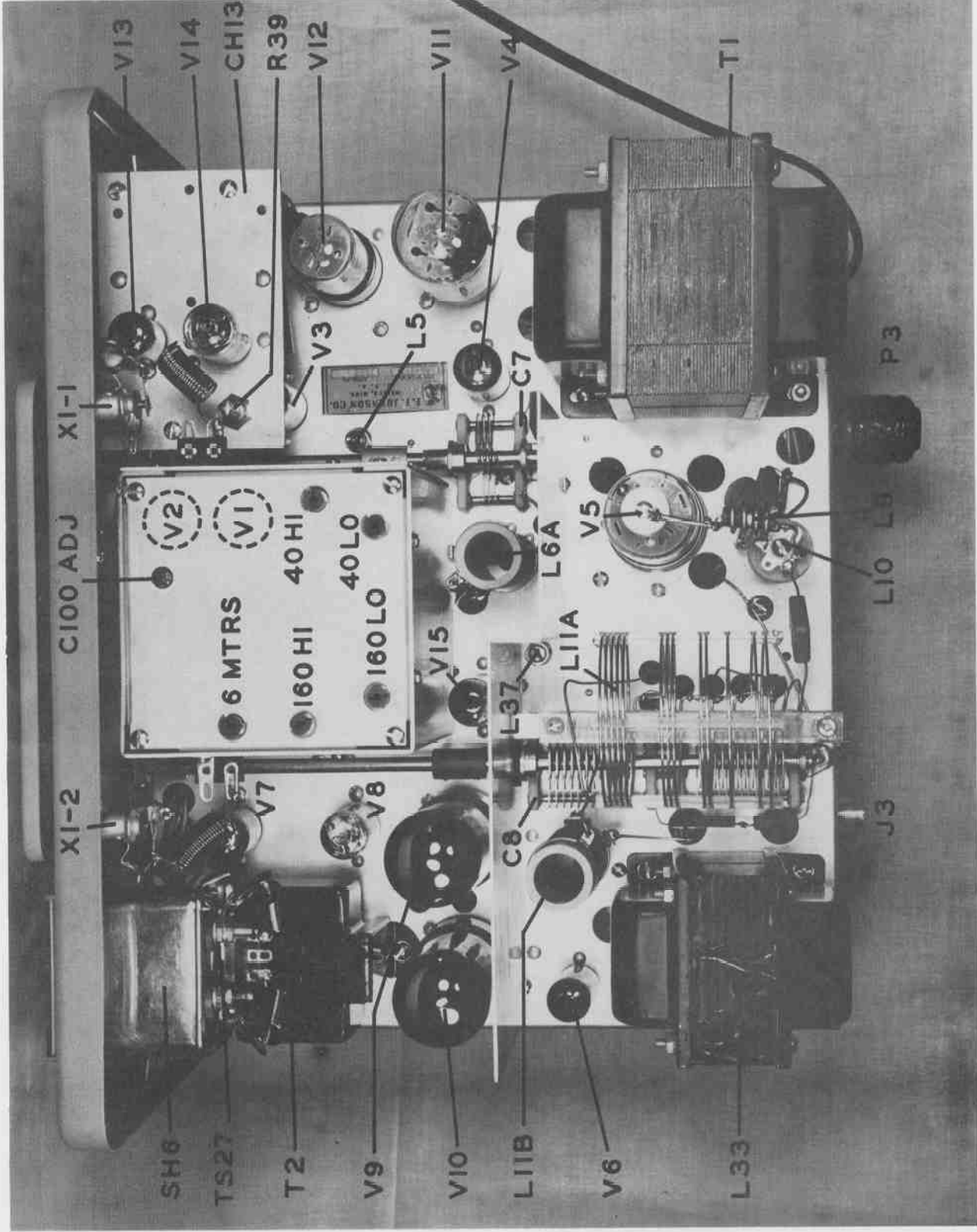

FIGURE II - COMPLETED CHASSIS TOP VIEW

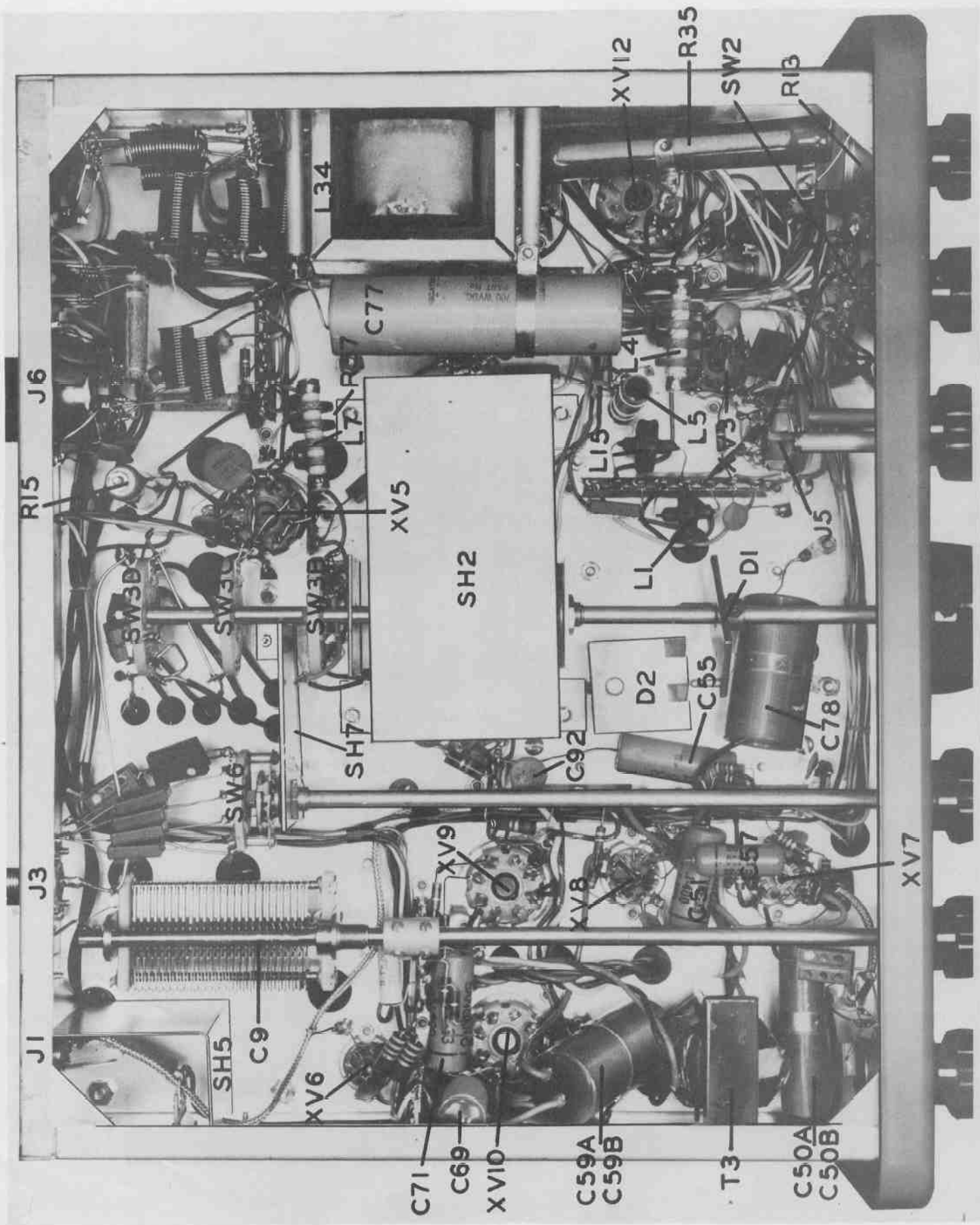

FIG. 12
 COMPLETED CHASSIS BOTTOM VIEW

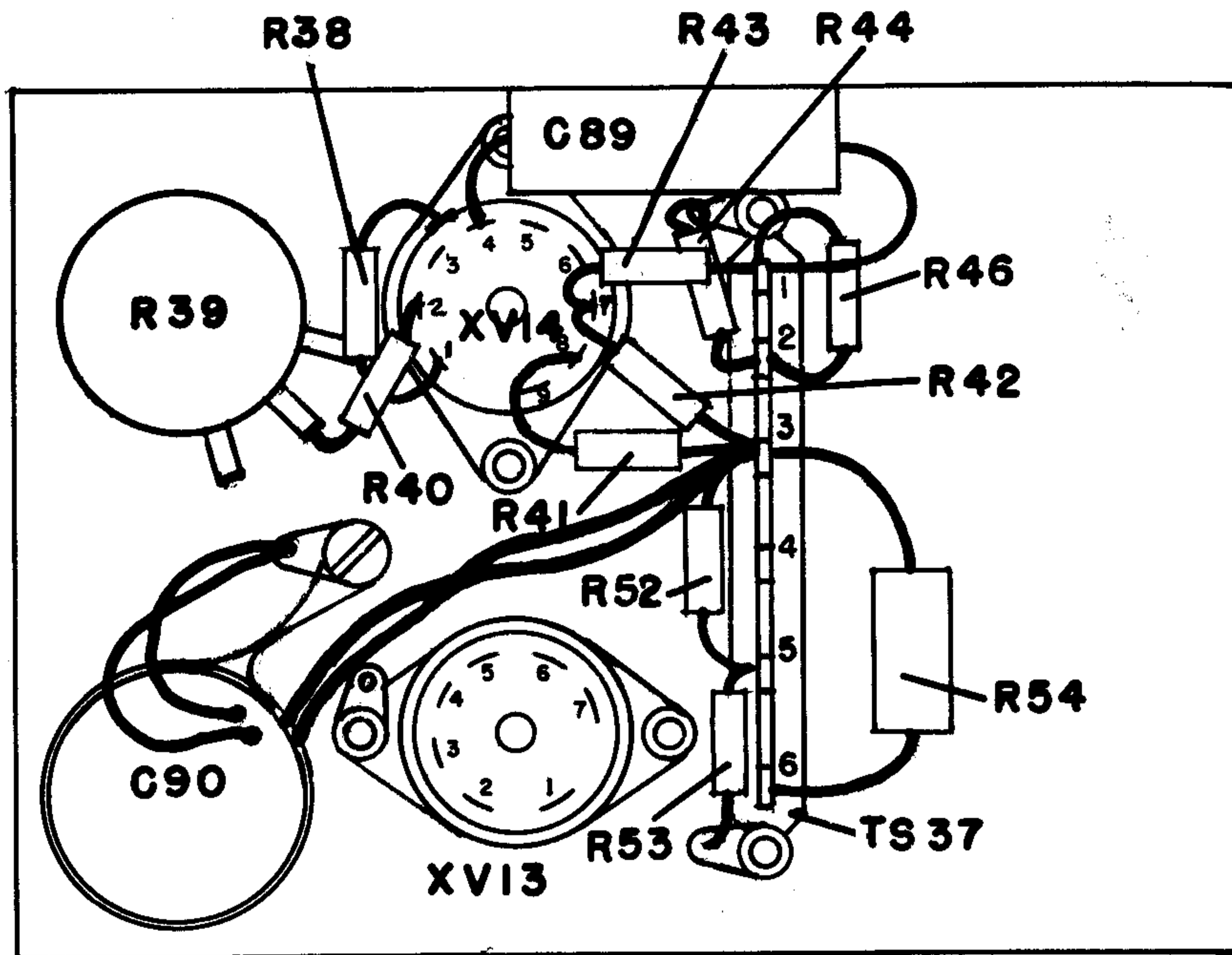

FIGURE 13A KEYER BOTTOM VIEW

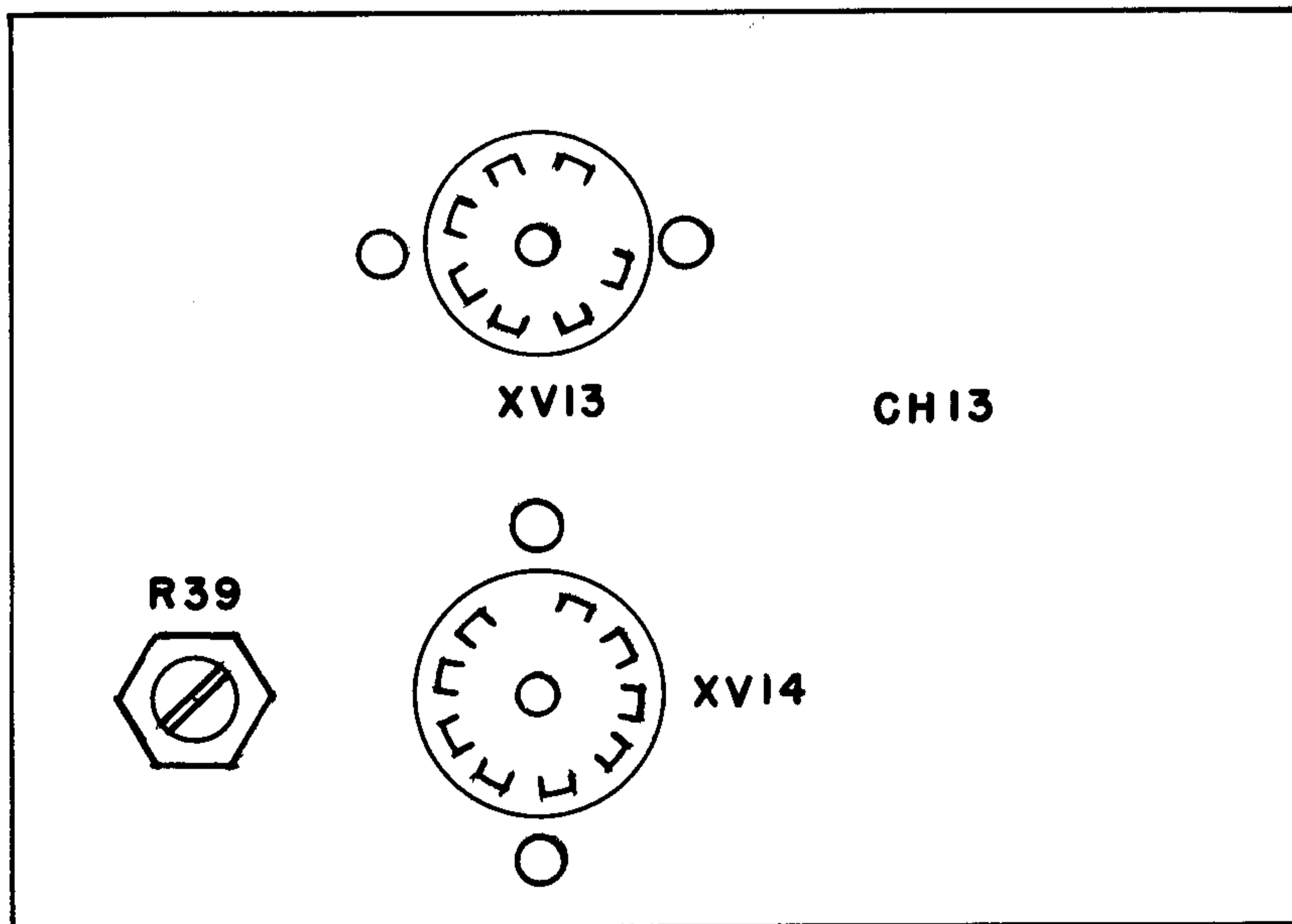

FIGURE 13B KEYER TOP VIEW

K4XL's **BAMA**

This manual is provided **FREE OF CHARGE** from the "BoatAnchor Manual Archive" as a service to the Boatanchor community.

It was uploaded by someone who wanted to help you repair and maintain your equipment.

If you paid anyone other than BAMA for this manual, you paid someone who is making a profit from the free labor of others without asking their permission.

You may pass on copies of this manual to anyone who needs it. But do it without charge.

Thousands of files are available without charge from BAMA. Visit us at <http://bama.sbc.edu>